

INDEX

Used materials	4
Technical smart features	6

INFLATABLE KAYAKS 9

RUSH	11
THAYA	13
TWIST	15
SWING	17
SOLAR	19
FRAMURA	21
SEAWAVE	23
SAFARI 330	25
K1, K2	27

INFLATABLE CANOES 31

RUBY XL	33
PALAVA	35
BARAKA	37
SCOUT	39
ORINOCO	41

INFLATABLE BOATS AND RAFTS 45

ONTARIO	47
COLORADO 450	49
PULSAR	51

INFLATABLE FISHING BOATS 55

HALIBUT	57
ALFONSO	59

OTHERS 60

Paddle	60
Accessories	62
Clothes	64
Boat description	66

LEGEND



Max. number of persons



Weight

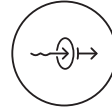

Self-draining bottom with a roll-top seal



Self-draining bottom



Motor attachment



Fast moving water with ripples and small waves.



Straightforward rapids with wide, clear and evident channels. Clearly visible rocks or other obstructions with medium-sized waves.



Rapids with moderate, irregular large waves which may be difficult to avoid. Strong eddies and powerful current effects.



Intense, powerful rapids requiring precise boat handling in turbulent water. It may feature large, unavoidable waves and holes.



Extremely difficult rapids with obstructions and dangerous currents. Drops may contain large, unavoidable hazards.



Drop-stitch technology used in the boat.



Maximum load

GUMOTEX HAS CELEBRATED 70 YEARS

Gumotex was founded seventy years ago in the very centre of Europe in The Czech Republic on the banks of the river Dyje (German Thaya), after which the revolutionary drop-stitch boat is also named. The writing of Gumotex's history began in 1950, when on January 9, in the premises of the former sugar refinery, the production of work and protective clothing and aprons made of rubberized textiles began. Then, in 1952, Gumotex started producing rubber toys, which for more than fifty years were part of most households in Czechoslovakia.



In 1963, a significant milestone in the history of Gumotex occurred. In the autumn the production of polyurethane foam began, which a year later was given the MOLITAN name. Today it is a world-famous brand, which the name of we owe to one of the employees of Gumotex from that time. Molitan foam is used in all fields of human life, such as the furniture industry, soundproofing or in the production of medical mattresses.

In 1956, Gumotex developed and manufactured the first inflatable boat. Originally, one could choose from only 3 or 4 basic models, based on a rubber tube with



a cover. However, within a few years, the boats had spread to most rivers and lakes in Czechoslovakia and became an important export item. Today, Gumotex boats are, thanks to their quality and durability, a perennial star not only on European waters but also overseas and Asia. When out on the water, you can sometimes meet boats which have been manufactured fifty years apart. Gumotex boats not only follow the latest trends, but thanks to our development centre, they bring completely new technologies to the market, and furthermore, the boats are often awarded at foreign trade fairs.

COMFORTABLE AND WELL DESIGNED SEATING POSITIONS AND SPACING

We design our boats to provide everyone with comfort and enough space all around. In addition to nobody kicking you in the back, you will also get the necessary paddle handling space.



THE PACKED BOAT IS EASY TO CARRY, FITS IN THE TRUNK OF A CAR AND ON BOARD AN AIRCRAFT



Most of our boats are supplied in a waterproof backpack to load on your back as you set off on your adventure. With every step you take you'll appreciate the reduced weight of our canvas rubber boats, compared to PVC.

NO SHIPWRECKS

Boats are made of highly durable material. Each contains at least 3 airchambers. If an accident occurs and one chamber deflates, the remaining two will keep you safely above the waterline.

WE MANUFACTURE RUBBER BOATS – THEY ARE ENVIRONMENTALLY FRIENDLY AND EASY TO REPAIR

One of the basic production materials of the boat is found between bark and wood of the para rubber tree. The boats are very durable due to great natural features and synthetic rubber blends that we develop. In the unlikely event of any issues the material is easily repaired with the kit supplied with all our boats.



WE'VE GOT YOUR BACK

We will support you throughout the life of your boat with any aftersales needs. Our boats are designed and built to last a long time, so to support this we continue to offer spare parts for superseded and discontinued models. We know the boats inside and out – from material development through to final product testing. Everything takes place under one roof and with a high proportion of handmade components



INTRODUCING THE SECRET OF OUR BOATS STRENGTH

We make everything from the beginning and so we have developed our own fabric based on natural rubber which guarantees excellent boat durability. They are resistant to abrasion, aging and sunlight.

NITRILON® DOUBLE-SIDED

Material composition: high-strength PES fabric (1) with double-sided synthetic rubber coating (2). The material is highly resistant to abrasion, ageing and UV. Tensile strength min. 3 000/3 000 N (sample 20 x 5 cm). Minimum weight 1 192 g/m².

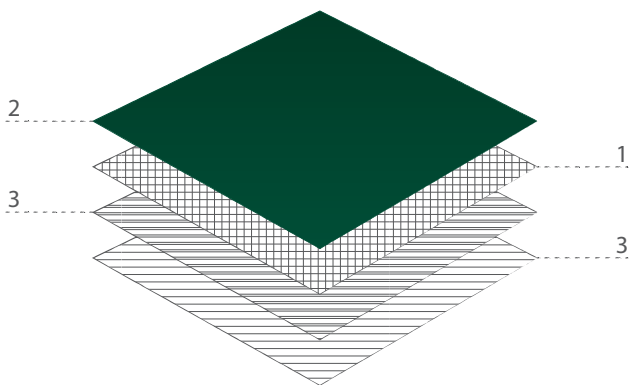
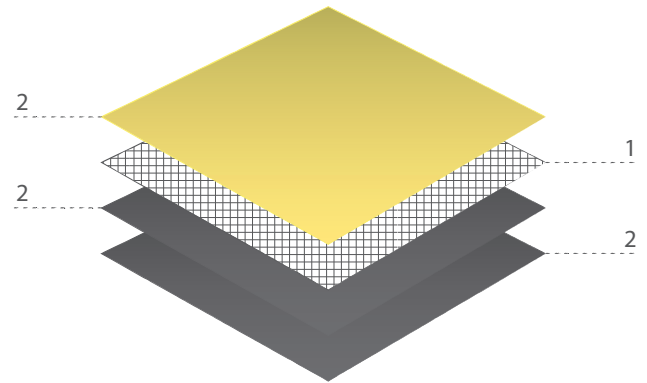

NITRILON®

Material composition: high-strength PES fabric (1) with outer synthetic rubber coating (2) and inner natural rubber blend coating (3). The material is highly resistant to abrasion, ageing and UV. Tensile strength min. 3 000/3 000 N (sample 20 x 5 cm). Minimum weight 920 g/m².

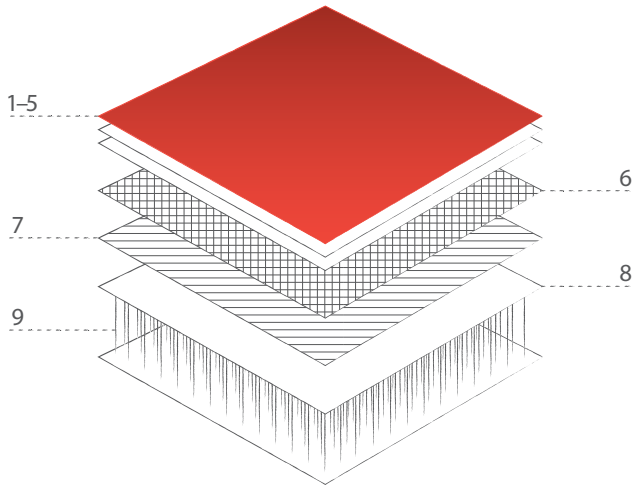

NITRILON® + DROP-STITCH

Material composition: outer coating based on synthetic rubber (1), anchoring layer (2), high-strength PES cloth (1 100 dTex) (3), anchoring layer (4), natural and synthetic rubber coating (5), natural and synthetic rubber coating (6), anchoring layer (7), top sheet of drop-stitch cloth (8), spacing fibres of drop-stitch cloth (9). Minimum tensile strength is 3 600/3 100 N (20x5 cm sample). Minimum weight is 1 270 g/m².

NITRILON® EXTRA

Material composition: high-strength PES fabric (1) with inner and outer layer of synthetic rubber (2) coating and outside NITRILON® EXTRA (3) coating. The top quality material for maximum load and for use in demanding climatic conditions. Tensile strength min. 3 000/3 000 N (sample 20 x 5 cm). Minimum weight 1 487 g/m².

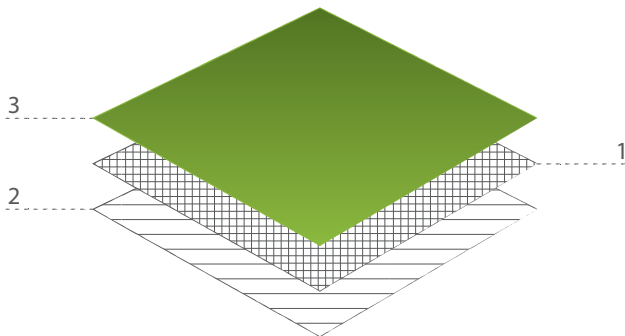
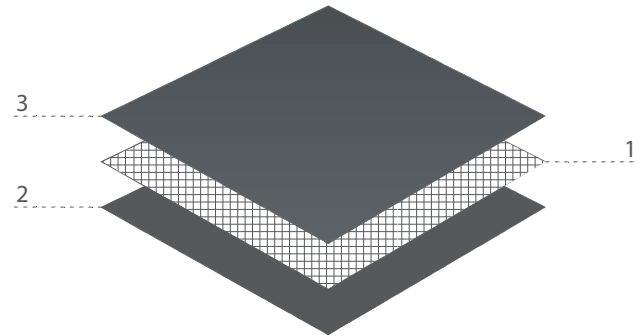

PES PUR

Material composition: PES fabric of RIPSTOP (1) type with inner polyurethane layer (2) and Teflon water-repellent finish (3). The material is abrasion, ageing and UV radiation resistant. Minimum pull strength 1 100/900 N (specimen 20 x 5 cm)

SMART TECHNICAL FEATURES:

SOLID BOTTOM USING DROP-STITCH TECHNOLOGY

The bottom is reinforced by thousands of fibres connecting its inner walls. Thanks to this the boat is very stable and difficult to capsize.

Included on: THAYA and RUSH kayak.

drop-stitch material

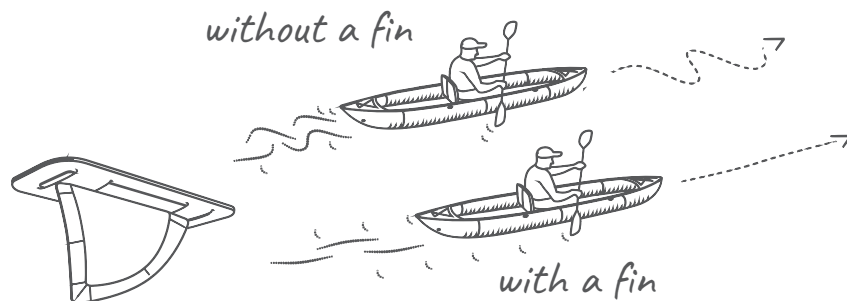
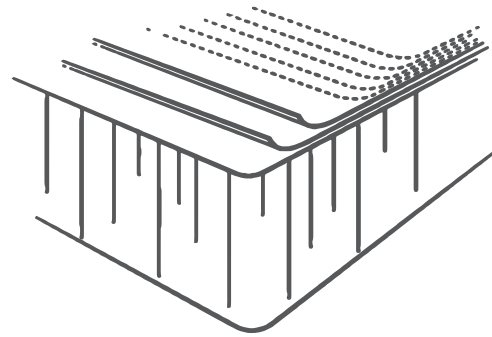

TRACKING FIN HELPS TO STEER COURSE

The tracking fin makes much easier to control the kayaks. Ensuring the boat tracks well and maintains good directional stability.

To be found at: THAYA, RUSH, TWIST, SWING, SOLAR, FRAMURA, SEAWAVE, SAFARI 330 and HALIBUT kayaks.

SELF-BAILING BOTTOM WITH A ROLL-TOP SEAL

When tackling rapids, getting some water in the boat is unavoidable, but thanks to the self-bailing floor design the water will drain away without effort. The rolling closure allows the floor to be sealed for calm water use.

To be found at: BARAKA, SCOUT Standard and ORINOCO boats.

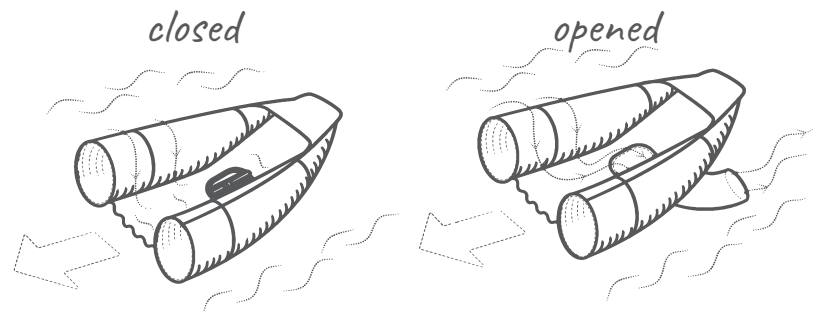

T-BONES REINFORCEMENTS

Metal reinforcements placed under the seats serve to shape and reinforce the bottom of the boat. Actually, the inflatable boat gains the performance characteristics of a hard-shell canoe.

To be found at SCOUT Standard canoe.

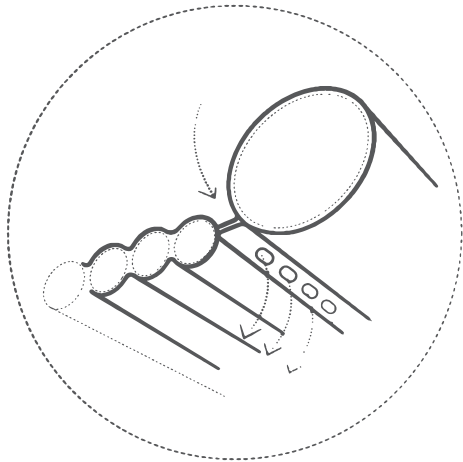
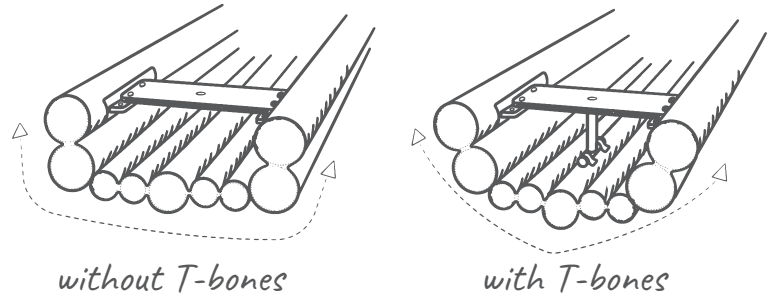

SELF-BAILING BOTTOM WITH DRAINAGE HOLES

Unobtrusive holes in the bottom of the boat will ensure you stay dry through more ferocious rapids. With water draining immediately.

To be found at: SAFARI 330, K1, K2, ONTARIO 450S and PULSAR boats.

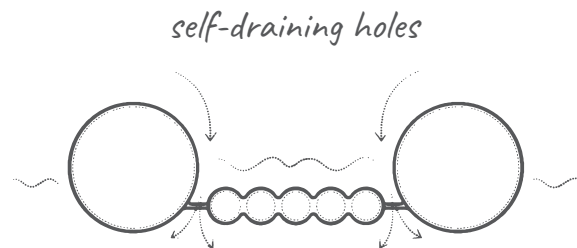

COMFORT ABOVE ALL ELSE

Even if you attach a third seat to your SEAWAVE, SOLAR or THAYA kayaks, each paddler will still have plenty of room and comfort. We respect the rules, and so all our boats comply with legal standards. As for boat capacity, we often supersede the standards.

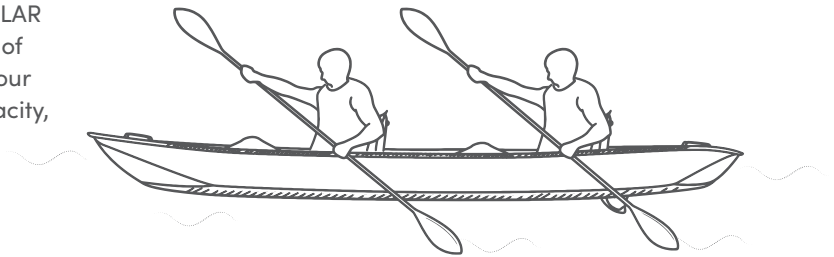



GUMOTEX

BOATS FOR EVERY OCCASION

Inflatable kayaks are stable, safe, easy to use and easy to pack. Recreational kayaks are designed for paddling on calm water such as lakes or coastal estuaries. White-water kayakers are designed for experienced paddlers for river descents with a higher degree of difficulty.

Rush



page 11

Thaya



page 13

Twiz



page 15

Swing



page 17

Solar



page 19

Framura



page 21

Seawave



page 23

Safari



page 25

IK₁ *IK₂*



page 27

Rush



RUSH 1



RUSH 2



FUTURE SOLVED...

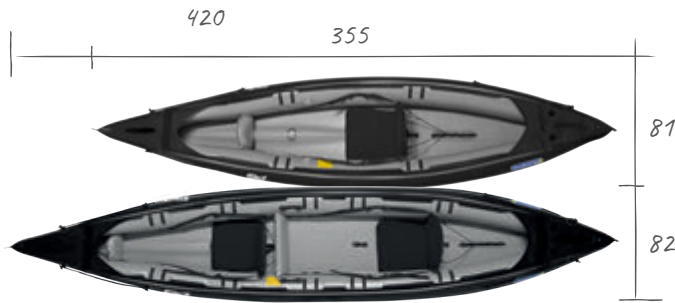

comfortable seat and backrest constructed from PE foam

deck rigging for fixing baggage

carry handles for ease of transport

drop-stitch bottom



fixture for tracking fin
tracking fin

safety ropes on the bow and stern

An innovative and versatile kayak design which further expands the possibilities of **drop-stitch** technology (hydrodynamically designed bow and keel). **RUSH** is suitable for recreation, touring, calm lakes, coastal waters as well as navigating white water up to grade 2. For better comfort in poor weather conditions, it can be equipped with a rudder or a removable cockpit (recommended accessories). The main advantages are versatility, speed and stability.

RUSH 2 kayak can be used as a single or as a double kayak.

Drop-stitch technology is based on the connection of the upper and lower layers of the fabric with thousands of polyester fibers. This fabric, equipped with an airtight coating, is protected from both sides by a resistant **NITRILON®** material. Thanks to the thousands fibers holding both layers together, these products can be inflated up to very high pressure. It enables the material to obtain robustness approaching the robustness of solid materials, and that is with the preservation of the same rollability as our existing boats.

Thaya



KAYAK WITH INFLATABLE, SOLID BOTTOM

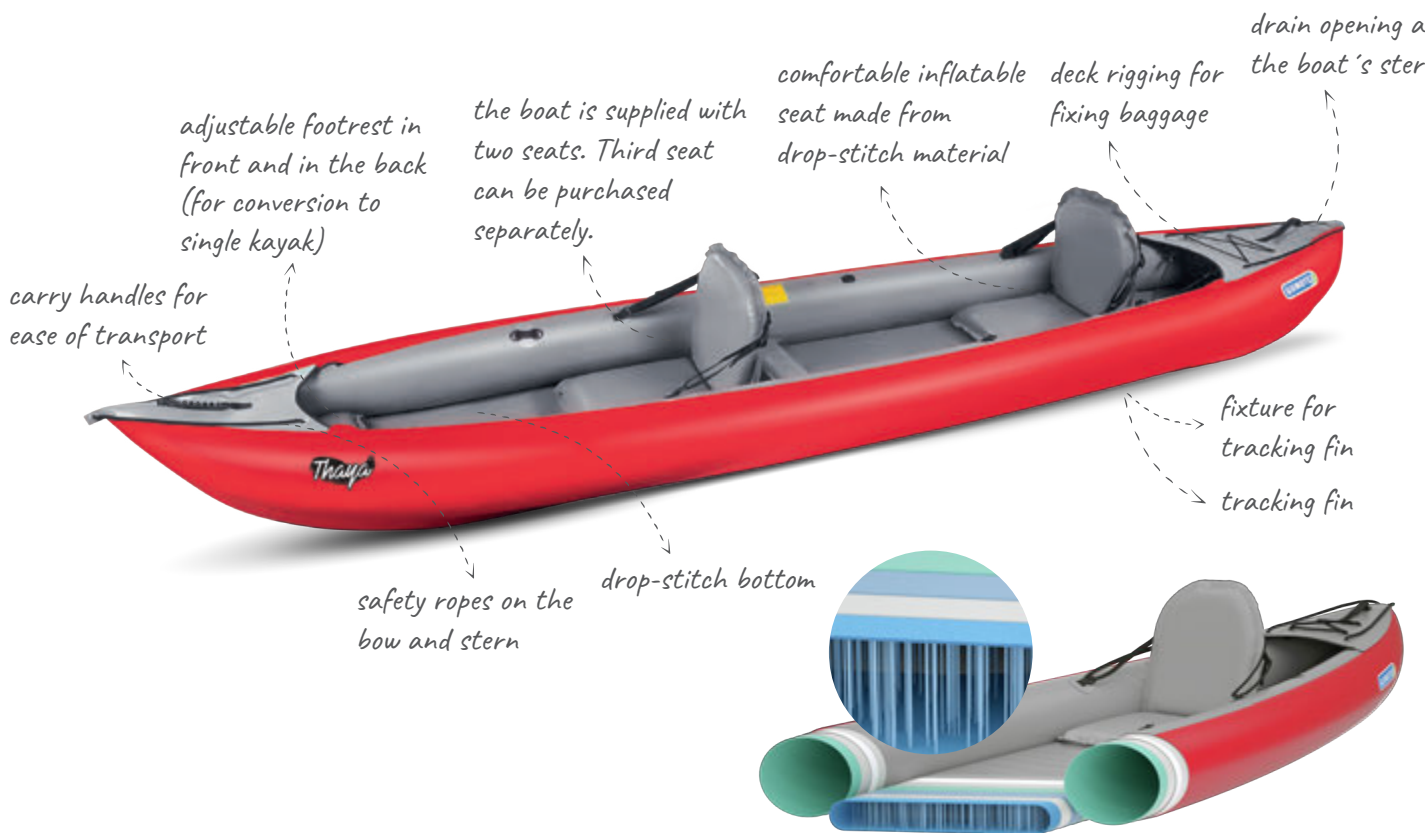

The revolutionary **THAYA** inflatable kayak uses a combination of our special **NITRILON**® material with **drop-stitch*** technology and is defined by its excellent stability, stiffness and maneuverability. The unique combination of the inflatable side tubes and modern **drop-stitch*** technology creates an universal combination which maximizes the user's comfort and improves the handling properties of the boat. Light-weight and easy to pack away are added benefits of the **THAYA**.

It is suitable for the recreational paddling on lakes, gentle coastal waters and rivers up to Gr. 2. Seating positions can be adjusted for 1, 2 adults or 2 adults +1 child. Optional foredeck splash cover offers protection for the front paddler and prevents water flowing over the bow

TWIST



TWIST 1



TWIST 2/1



LIGHTWEIGHT KAYAK FOR EVERYONE

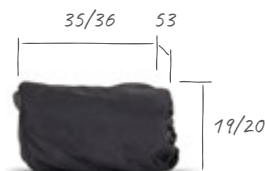
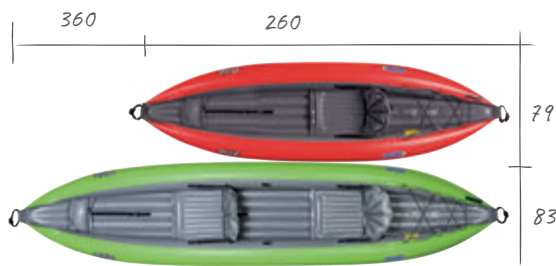

Are you looking for a small, lightweight, space-saving kayak as a companion on the road and your watersport adventures? Then the **TWIST** is the right choice for you, whether exploring new places on lakes or travelling on calm rivers. The **TWIST 1** is the smallest and the lightest kayak from our fleet.

The **TWIST 2/1** can be easily transformed from its two-seat version to its one-seat version or vice versa, thanks to an innovative design. The kayak is stable enough for a variety of paddler sizes, and comfortably fits two people.

SWING



SWING 2 SWING 1



A STABLE PARTNER FOR TRICKY SITUATIONS

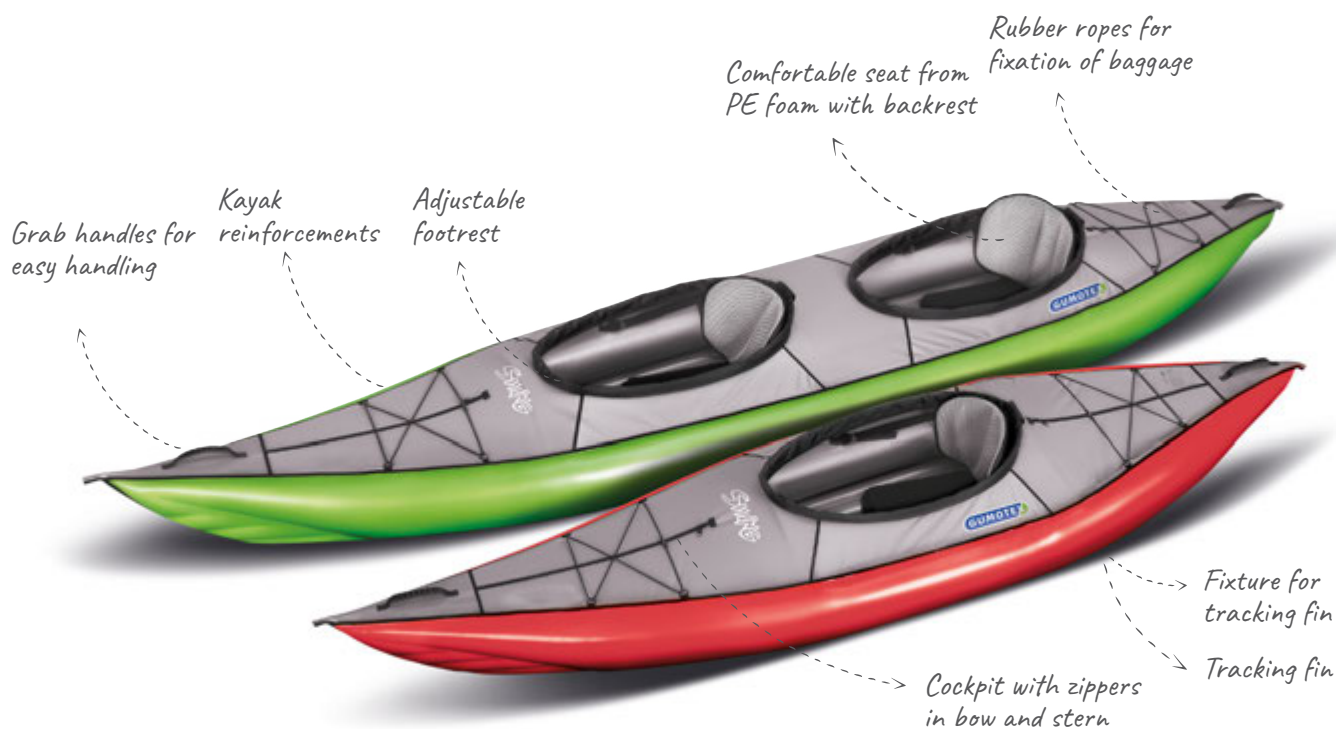
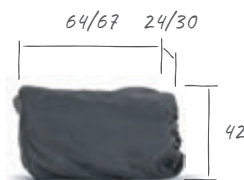
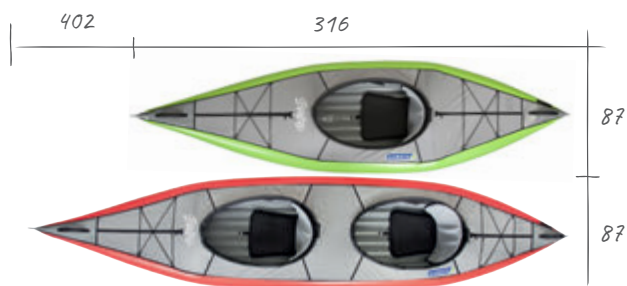

on sheltered waters, harbours, lakes and rivers up to Gr. 2. The kayak is supplied with two aluminium reinforcements for improved rigidity of the hull, maneuverability and stability.

The reinforcements also shape the deck of the kayak.

Thanks to its low weight the kayak is perfect for trips with frequent portages. The kayak is available in a single and a double version.

Solar



A FAMILY KAYAK THAT ALMOST PADDLES ITSELF

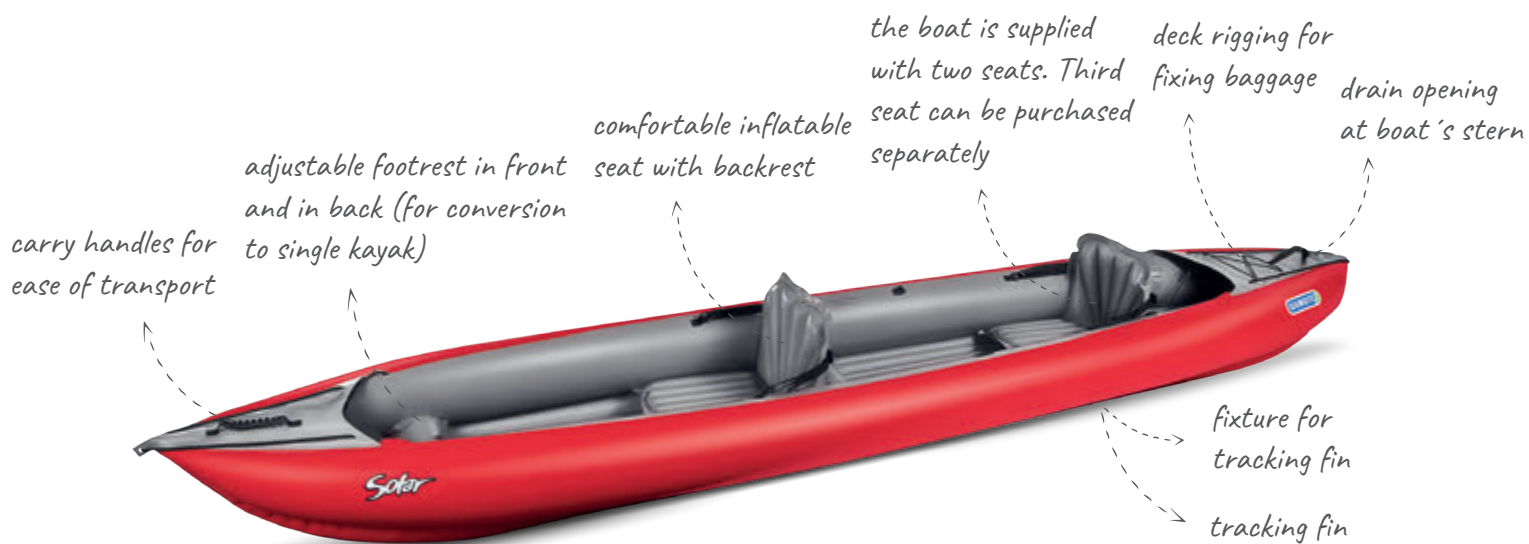
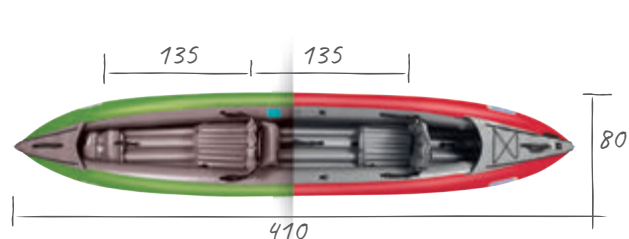

The **SOLAR** inflatable kayak serves for both trips on lakes and touring on rivers up to Gr. 2. An optional foredeck splash cover offers protection from the elements for the front paddler and prevents water flowing over the bow. The kayak is equipped with a drainage hole in the rear deck.

The **SOLAR** is equipped with two seats and fixtures for an optional third seat. As a result, the **SOLAR** boasts versatility with paddling setups for solo, tandem or 2+1 use.

Framura



THE FASTEST GUMOTEX KAYAK

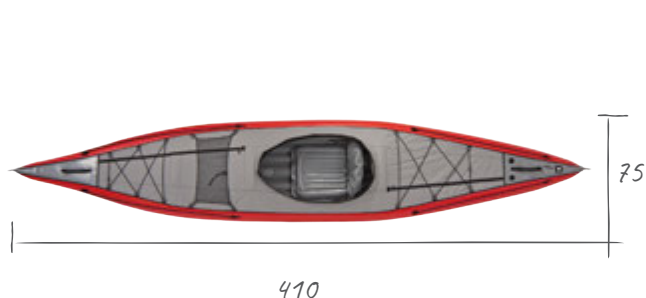

FRAMURA is the fastest kayak produced by **GUMOTEX**. It is designed for leisure and touring and is suitable for sheltered waters, harbours, inlets and lakes as well as calm rivers up to Gr. 1. **FRAMURA** has carrying capacity in the

front and rear. The kayak has a fixed deck, elastic netting and a comfortable inflatable seat: it's a feature rich touring, kayak with optional spray skirt and rudder. A sea-kayak paddle is an ideal choice for **FRAMURA**.

Seawave



THE ULTIMATE GUMOTEX TOURING KAYAK

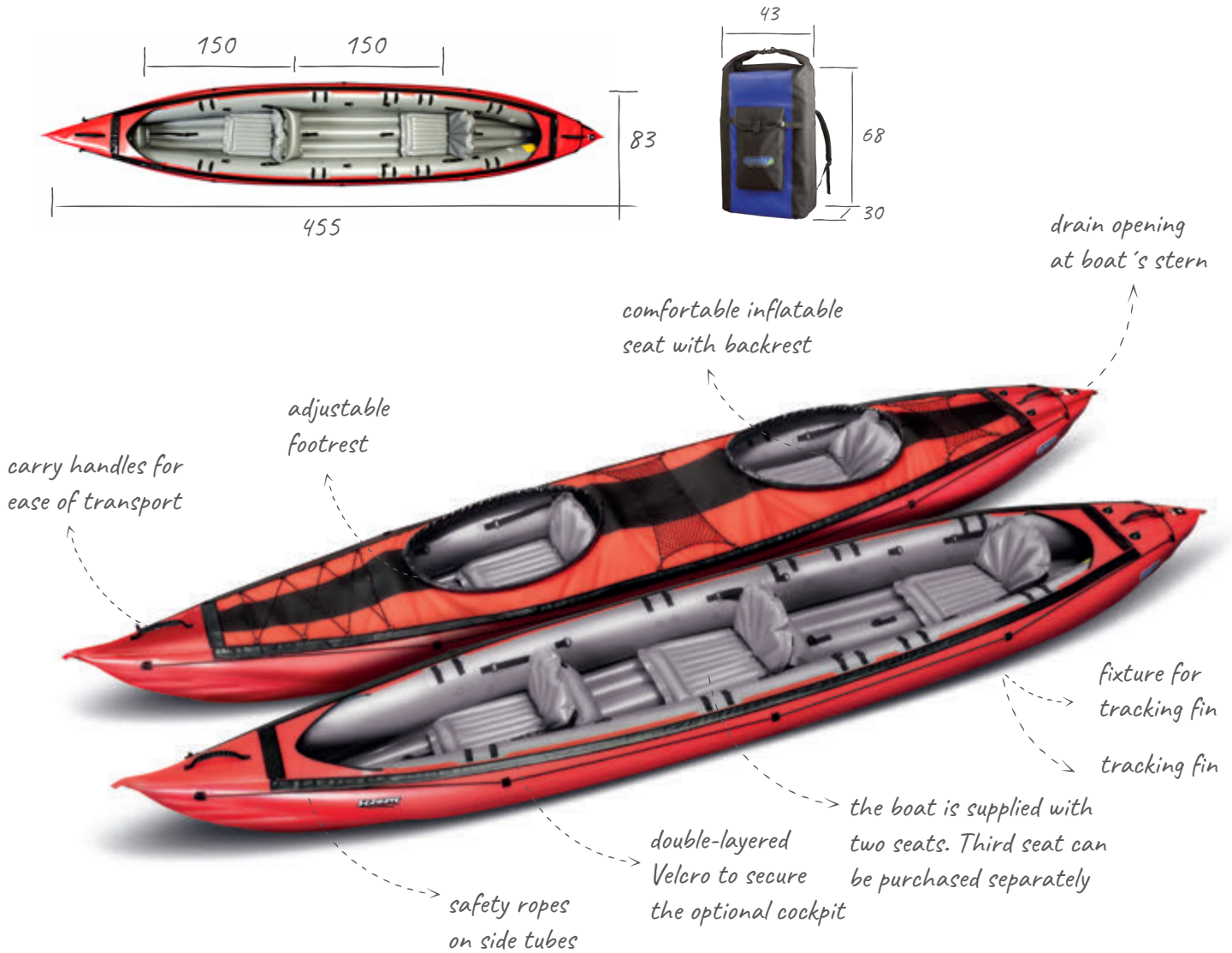

Thanks to its long narrow shape, the **SEAWAVE** kayak is easy to control and very fast. It can be converted from a three-person version into a two-person or one-person kayak by moving the seats. Installation of an optional deck makes **SEAWAVE** a great sea kayak.

Aluminium reinforcements support the deck and stiffen the kayak. The floor features a pronounced keel for handling in the wind and better tracking. **SEAWAVE** is an excellent touring kayak suitable also for sea kayaking in sheltered waters.

Safari



FUN KAYAK FOR RIVERS AND SEA SURFING

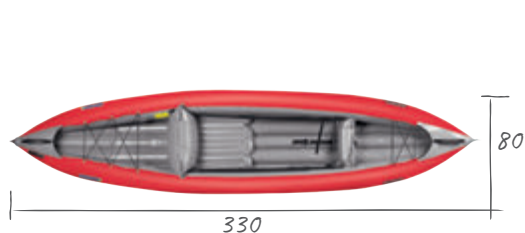

SAFARI 330 is a sports kayak with a self-bailing bottom suitable for rivers up to Gr. 3 white water, coastal kayaking or surfing. The new **SAFARI 330** is longer, wider and more stable than its precursor.

It is spacious enough to fit well-built kayakers and thanks to significantly improved stability suitable even for less

experienced paddlers. The stern and bow can accommodate dry bags with your personal gear. Elastic ropes secure the bags in place.

K₁

K₂



K1



K2



DURABLE WHITE WATER KAYAKS

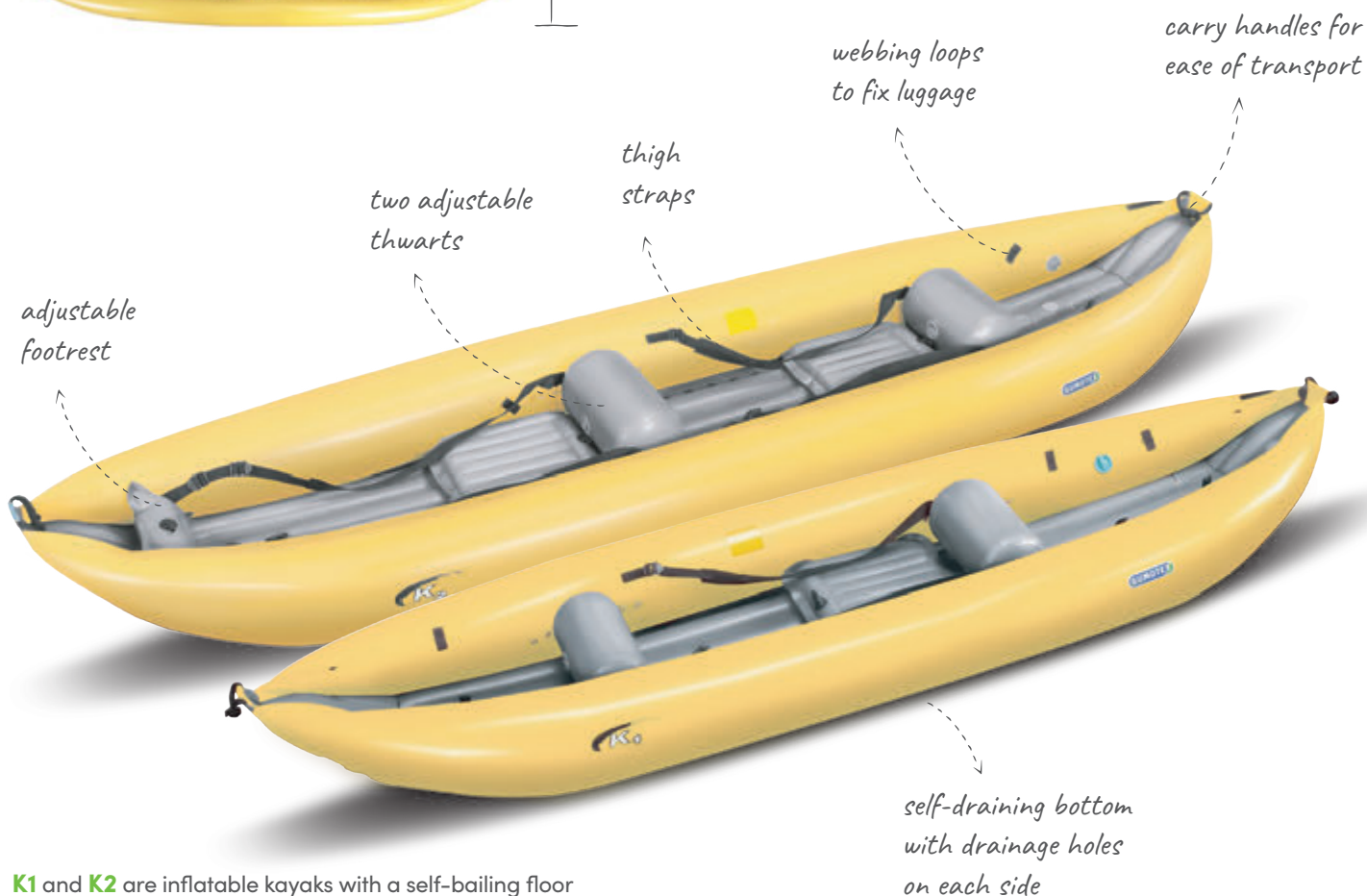
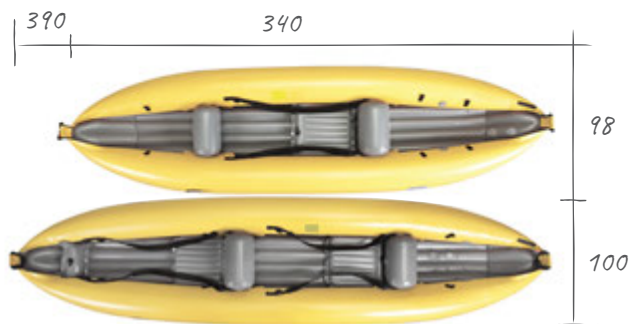

K1 and **K2** are inflatable kayaks with a self-bailing floor designed specifically for white water. The kayak is very stable and forgiving making it confidence inspiring for novice kayakers, even on more technical runs. Both **K1** and **K2** offer ample seating space and an inflatable seat(s) for comfort plus thigh straps for better control of the kayak in rapids.



„WITH SEA KAYAKS FROM GUMOTEX WE EXPERIENCED **THE BEST** **VACATION OF OUR LIVES.**“

Irena and Jiří Páleníčkovi, journalists

We took over this sentence from our friend. When we were planning our second trip to the Greek islands, we praised the first one until they said, „So you know what? Lend me the kayaks, we will go first, and in six weeks we will give them back to you on the Greek island of Kefalonia.“ Two months later, they waved at us laughing, tanned, happy and shouting: „That was the most beautiful tramp in our lives!“

Instead of our old heavy Seaker, Gumotex now makes a lighter and improved Rush, but in each of them you can experience the best seaside vacation. No matter whether you have a double kayak or, like us, everyone has his own. And the great thing was (and is) the fact that we bought everything at once, from the pump to the transport bags, which are of high quality so that we use them even when we are on our bicycle tours.

The carrying capacity of these inflatable boats is admirable, we took in them supplies of wine and water, food, photographic utensils, a tent, sleeping bags, a stove and everything a person needs for a sea journey outside of

civilization for a week. We could enjoy rummaging around on the shore.

From June to September, the kayaks took us from beach to beach. You do not have to play Robinsons like us, but one night on a beach where the road does not lead to will suffice to fall under their spell and to start thinking, like us, what will be the next destination.

P.S. We tried in vain to capsize them. We failed. (This summer we tried a cute toy kayak Swing, which we packed additionally in the camper van. Although unlike my husband, I am no water specialist, I could not capsize in the Swing and I swam across the surface like a duck).





AN IDEAL PARTNER FOR LONG JOURNEYS

Inflatable canoes are safe, easy to use and easily packable. They excel in their speed and agility, and also have plenty of storage space. Inflatable canoes are intended primarily for overnight trips and exploring waters with a lower degree of difficulty.

RubyXL

page 33



Scout

page 39



Palava

page 35



Baraka

page 37



ORINOCO

page 41



RubyXL



RECREATIONAL BOAT WITH OPTIONAL MOTOR ATTACHMENT



The new, larger boat **RUBY XL** is 17cm wider than the original version while maintaining an excellent handling performance. It can be used with oars, with paddles as a canoe, or with a motor. The fastening of the transom has also been improved, which is now much more robust and can be fitted with a motor with the maximum power up to 5 hp = 3.7 kW.

The **RUBY XL** boat is suitable for recreational coastal use, or just trips on lakes and quieter watercourses. With canoe paddles, without motor and oars, this boat can be used for river cruising up to the Gr. 2.

Palava



EVERGREEN OF EUROPEAN RIVERS



The **PALAVA** inflatable canoe is eye catching with its sporty look and excellent handling performance. Thanks to its longer hull, it offers a storage space and a flexibility of seat positioning provides comfort for anyone. When riding in rapids, it is possible to kneel and use the thigh straps. The canoe is suitable for river cruising up to the Gr. 3 as well as for a comfortable touring on placid natural and artificial lakes.

Baraka



SPORTS CANOE WITH PLENTY OF SMART FEATURES

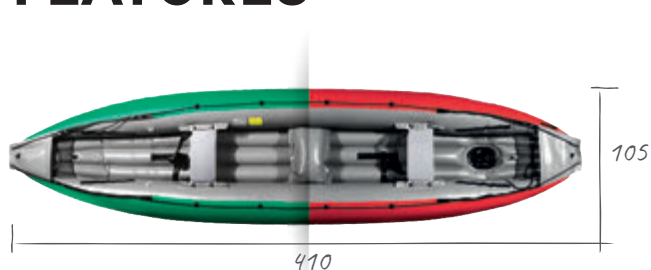

BARAKA is a river canoe with a self-bailing floor that can handle white water up to Gr. 4. The boat has a rigid hull that handles well in rapids. BARAKA provides its crew with many useful features and fittings and with plenty of space inside. The boat is designed for two adults plus a child, up to 350 kg max load. BARAKA is the right choice for paddlers, who are looking for a boat designed without compromises.

Scout



SCOUT
STANDARD



SCOUT
ECONOMY



COMFORTABLE CANOE FOR LONG EXPEDITIONS

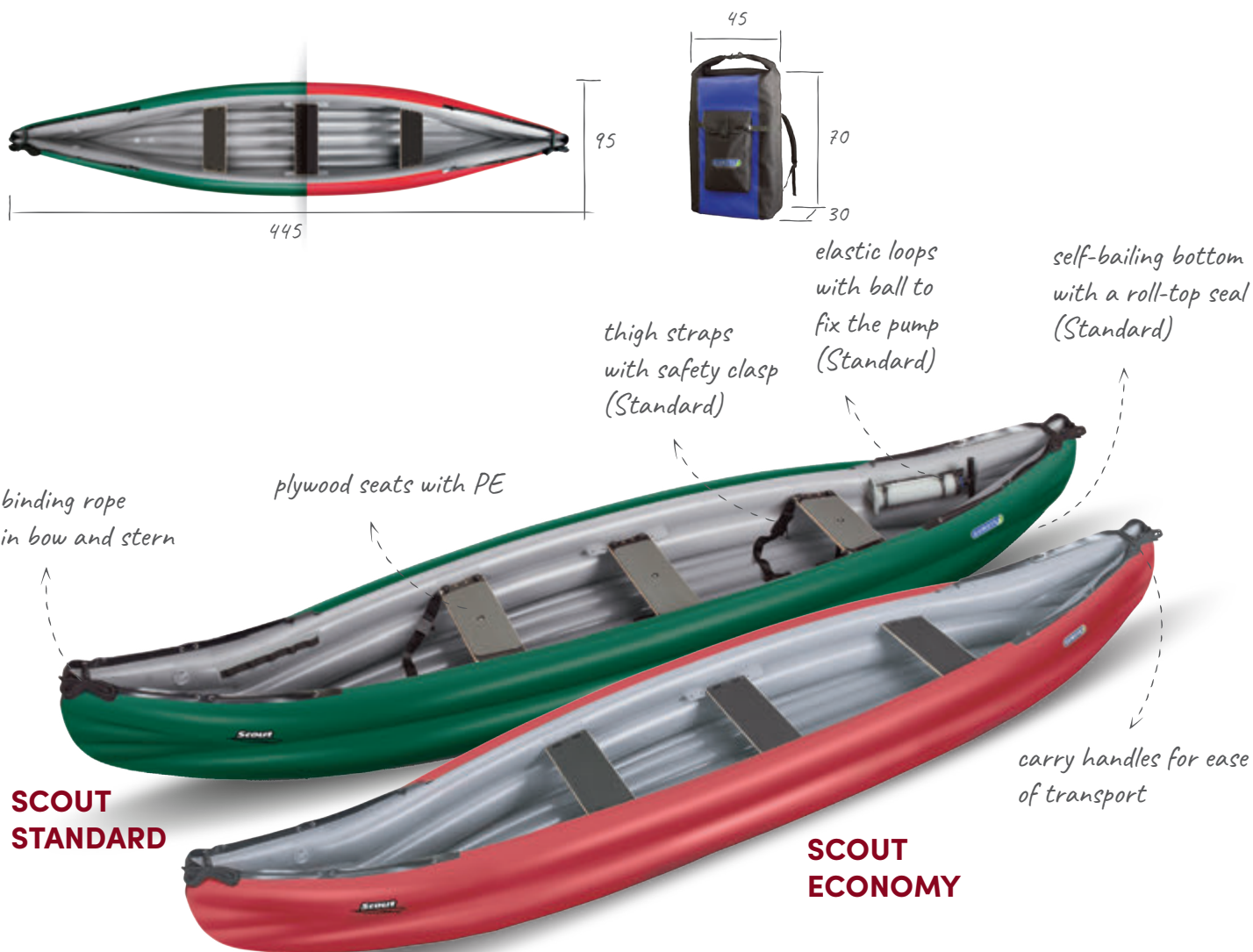

SCOUT is an inflatable canoe with a modern design. The boat offers plenty of features for the paddler's comfort and convenience, such as large inner space combined with huge payload and smooth handling. **SCOUT** makes an ideal boat for adventures with plenty of carrying capacity, suitable for white water enthusiasts or for family trips.

This boat is available in a **STANDARD** or **ECONOMY (S/E+)** version. **STANDARD** version brings an innovative system of **T-BONES** reinforcements that strengthen the boat's floor and provide great handling qualities comparable with a rigid canoe.

ORINOCO

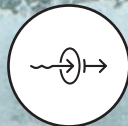

DURABLE TANDEM BOAT



carry handles for ease of transport

plywood seats with PE foam "COMFORT PAD"

thigh straps with safety clasp

attachment points in the bow and stern

self-bailing bottom with a roll-top seal

safety grab handles in bow and stern

ORINOCO is a multi-purpose inflatable boat suitable for river cruising, overnight trips and expeditions, white water, and it also makes a great family boat. The river raft-like design provides experienced paddlers with essential stability while running white water. Thigh straps with safety clasp provide better control in rapids.

**BOATS ARE MADE OF DURABLE MATERIAL
AND WILL KEEP YOU ABOVE WATER IN
EVERY SITUATION**







BOATS CAPABLE OF TACKLING THE TOUGHEST WHITEWATER RAPIDS

Inflatable boats and rafts from this category are designed for both experienced paddlers to take on rapids and for multi-day trips with the whole family or a set of friends. These boats are robust, durable and safe. We have equipped them with a self-bailing bottom and many safety elements. We recommend using a buoyancy aid, helmet and suitable clothing.

Ontario

page 47



PULSAR

page 51



Colorado

page 49



Ontario



ONTARIO
450 S



ONTARIO
420



OUR FASTEST MULTI-SEAT BOAT

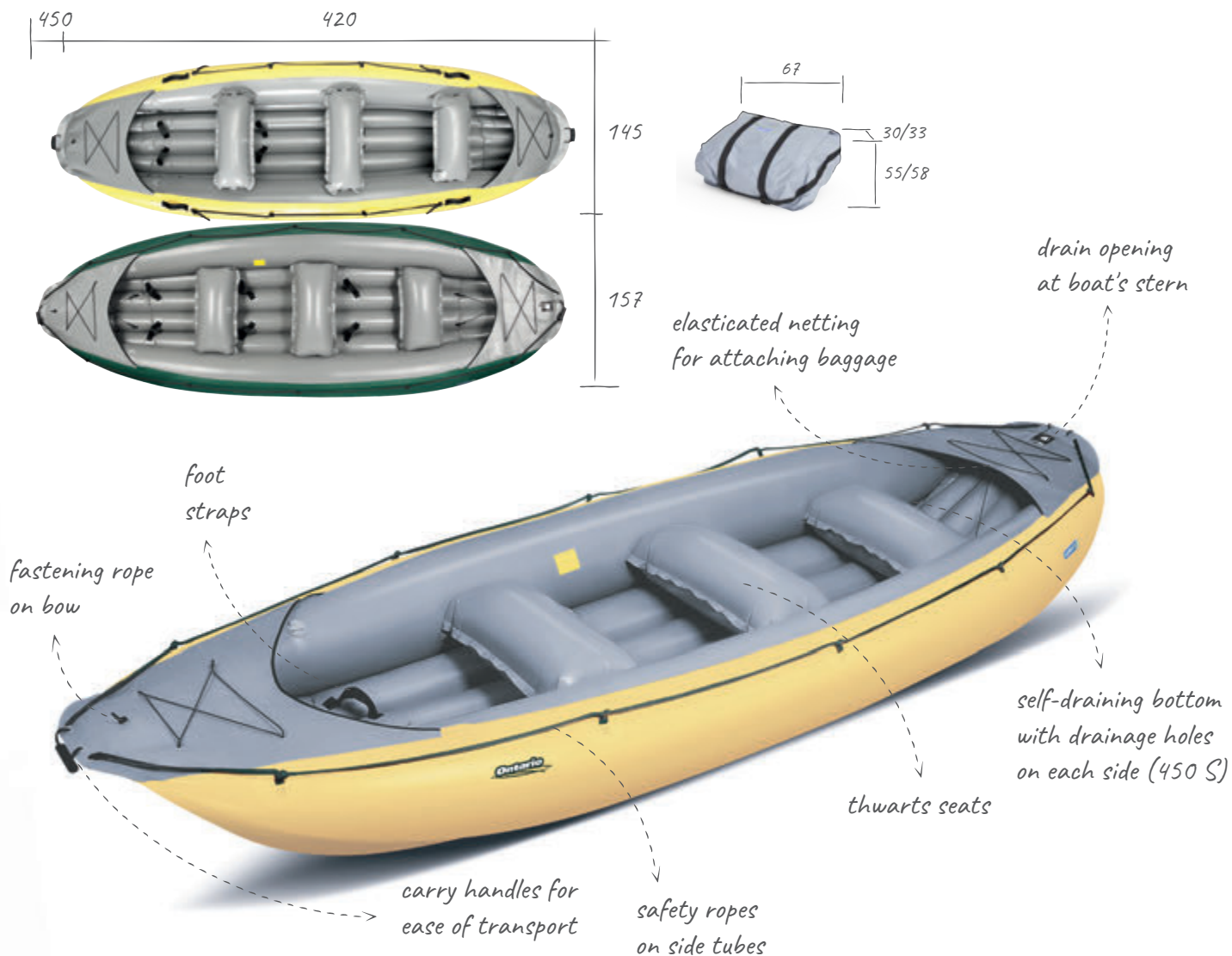

ONTARIO is a six-person boat suitable for multi-day trips on rivers with the whole family. **ONTARIO** is easy to control, fast and nimble. The shorter **ONTARIO 420** has non-bailing floor and is suitable for rivers with lower difficulty white water.

The new and larger **ONTARIO 450 S** is a self-bailing boat that can handle more serious rapids than the shorter version. **ONTARIO** is a versatile boat suitable for everyone.

Colorado



PERFORMANCE MULTI-PURPOSE BOAT

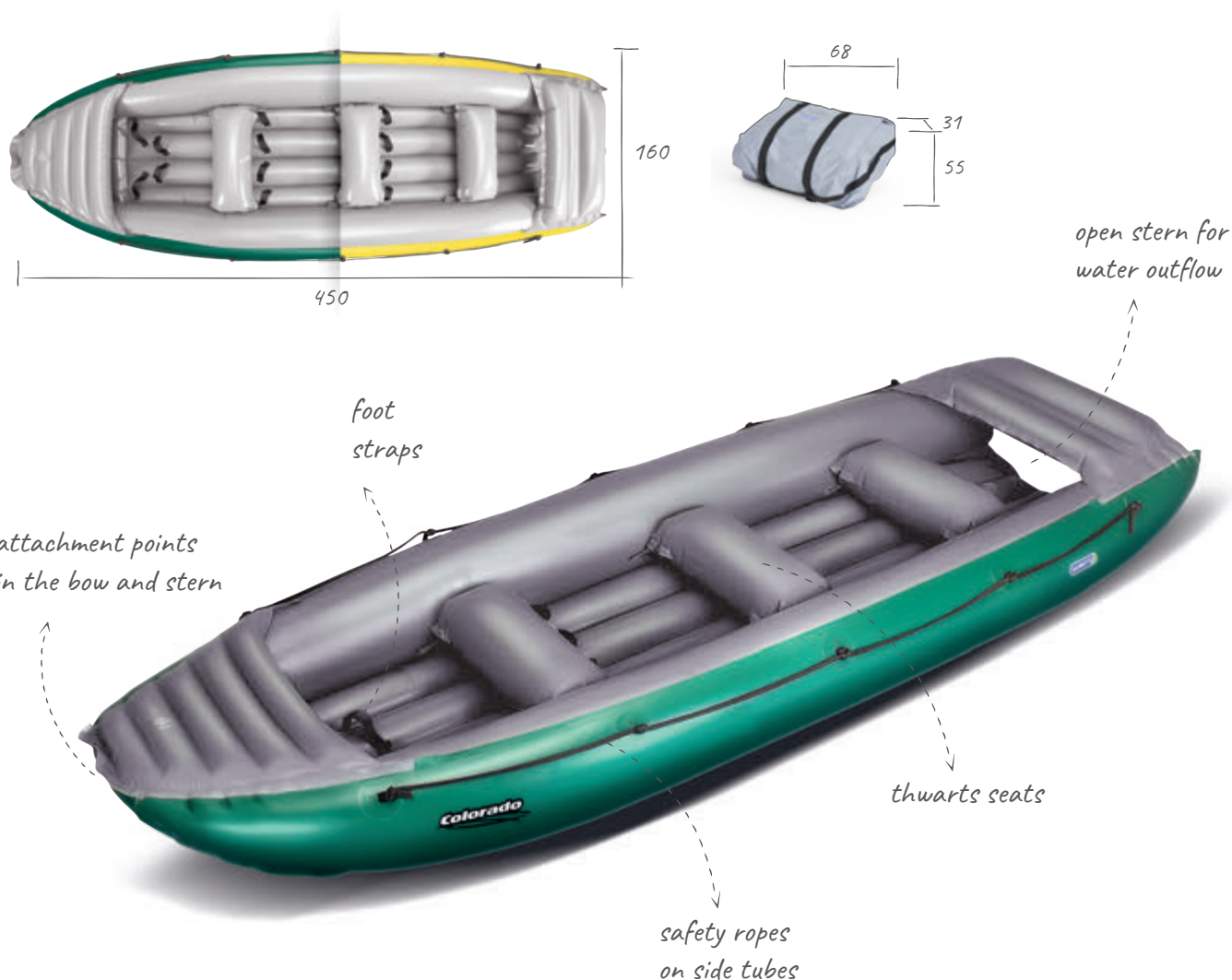

COLORADO 450 is a multi-purpose boat. This six-person boat is great for river cruising or performance white water with experienced paddlers. The open stern provides the outflow of water in rapids. The legendary **COLORADO** has served on many expeditions into remote places around the world and is still a very popular team racing river boat in the Czech Republic.

PULSAR



PULSAR
380



PULSAR
450



PULSAR
420



PULSAR
560



RAFT FOR THE TOUGHEST CONDITIONS

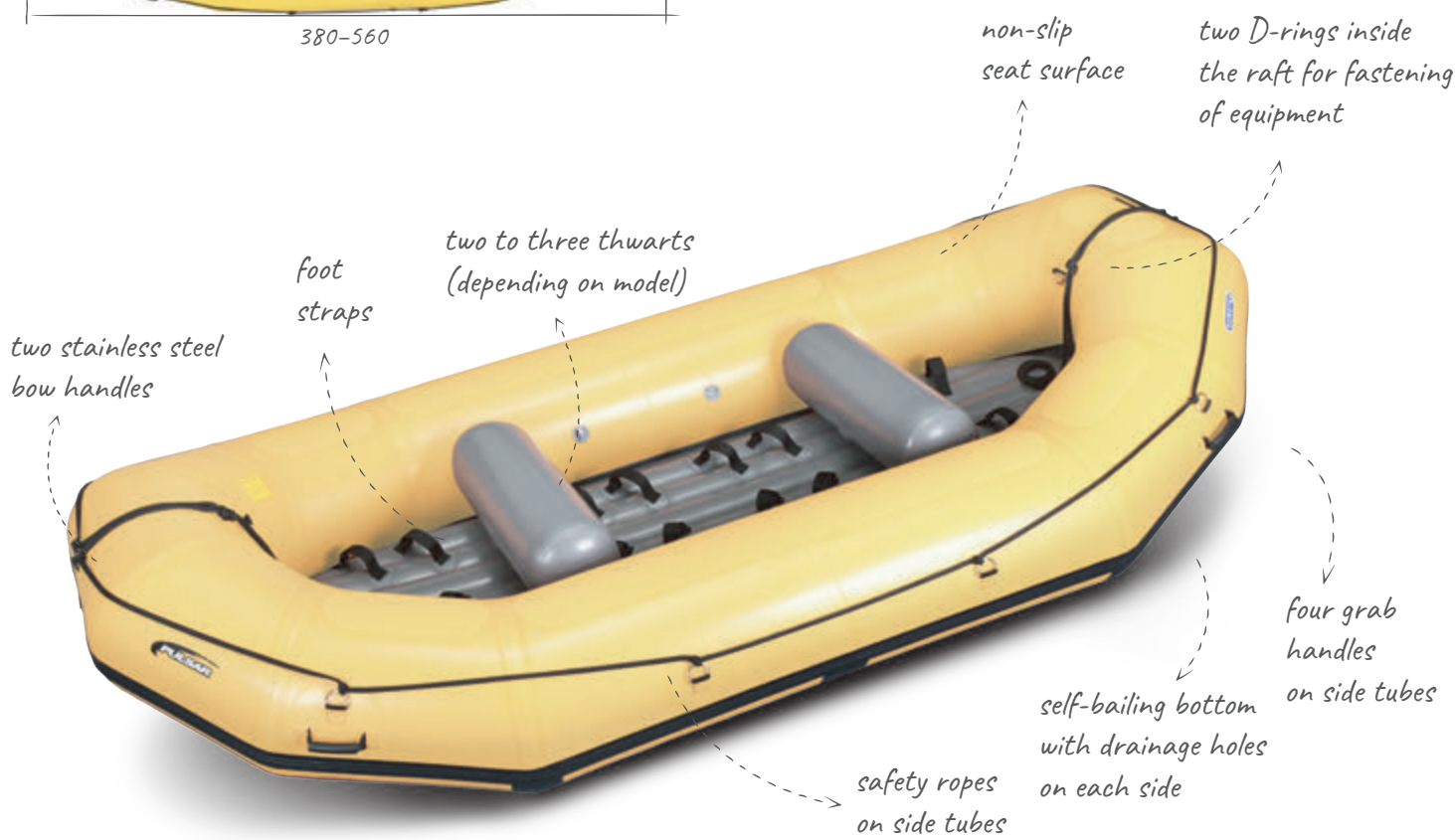
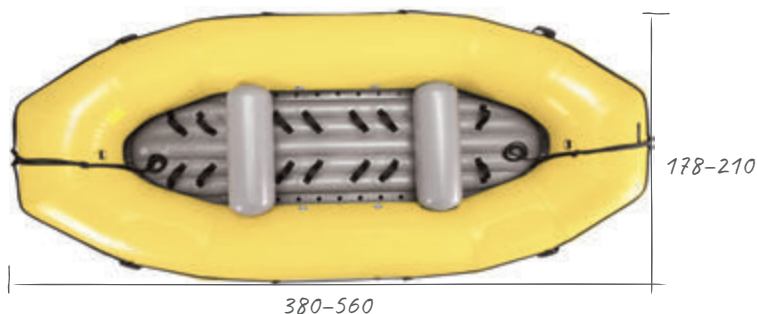

PULSAR are sought after by rafting operators, sports centres, water sports clubs and also for raft racing. The fast and rigid hull combined with the self-bailing inflatable bottom provides exceptional stability and very fast draining in rapids. **PULSAR** rafts have been chosen several times

as the official race boats for the European Championships (most recently for the European Rafting Champs 2016 in Slovenia) and also the official race boat for the 2003 World Championships that took place in the Czech Republic on the Vltava River.



BEST FOR PASSIONATE FISHERMEN

GUMOTEX inflatable fishing boats are designed for recreational and sports fishing. They provide a platform from which to fish. Their main feature is stability – they enable standing up while casting the line. The supplied accessories include comfortable inflatable seats with backrest, rod holders and other fishing equipment. These boats pack up in the carry bag provided and are easy to carry or store.

Halibut



page 57

Alfonso



page 59

Halibut



UNIQUE FISHING KAYAK

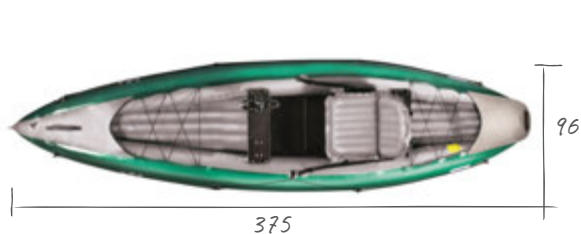

HALIBUT is an inflatable fishing kayak, offering a new dimension in the sport of angling. Thanks to its compact dimensions when packed, it is possible to enjoy kayak fishing even in remote locations. HALIBUT is very stable, responsive and fast when moving on the water.

The inflatable kayak floor is fitted with a marine plywood standing platform. A raised adjustable seat makes for easy embarking and disembarking and also provides comfort while waiting for a catch.

Alfonso



COMFORT BOAT FOR FISHERMEN



The updated **ALFONSO** fishing boat is mainly distinguished by its excellent stability and plenty of space for up to 3 passengers (or 2 fishermen). It can be used with oars, with paddles as a canoe, or in combination with a motor. The fastening of the transom has also been improved, which is now much more robust and can be fitted with a motor with the maximum power up to 5 hp = 3,7 kW. A new addition – the boat has 5 bases for mounting a wide range of holders and fasteners for accessories (4 bases are

placed on the side tubes because of a greater practicality, so they do not reduce the interior space of the boat, and the 5th base is intended for the eventual positioning on the middle or rear seat). This boat is suitable for white water up to Gr. 2 using paddles alone.

PADDLE



PADDLE TYPE 504 RAFTGUIDE

Rafting paddle with
a blade surface area
of 985 cm²

Length:
145, 150, 160, 170 cm

Weigh:
0,88 – 0,965 kg
(depending on size)



CANOE PADDLE TYPE 505 ALLROUND

Canoe paddles with
a blade surface area
of 802 cm²

Length:
145, 150, 160, 170 cm

Weigh:
0,72 – 0,90 kg
(depending on size)
505.0 one-piece,
505.2 two-piece,
505.3 three-piece



PADDLE TYPE 702.3 FISHING

Three-piece paddle
length 260 cm designed
for the HALIBUT fishing
kayak.

Length:
260 cm

Weigh:
1,55 kg



KAYAK PADDLE TYPE 702 ALLROUND

Traditional kayak paddle
with asymmetrical blade,
blade surface area 709 cm²

Length:
200 – 240 cm
increasing 10 cm

Weigh:
1,145 – 1,385 kg
(depending on size)
702.0 one-piece,
702.2 two-piece,
702.3 three-piece



PADDLE TYPE 703.2 SEA

Classic double touring
paddle for lakes and
sea touring, paddle
blade surface area
626 cm²

Length:
200– 240 cm
increasing 10 cm

Weigh:
1,24 kg
(depending on size)





PADDLE TYPE 801 COMBINATION

Either 2 canoe paddles or 1 kayak paddle can be assembled from this folding paddle, 736 cm² blade surface.

Kayak paddle length:
180 – 240 cm
increasing 10 cm

Canoe paddles length:
145 and 155 cm

Weigh:
1,31 kg
(depending on size)



KAYAK PADDLE TYPE 719S.2

A double paddle on glass laminate spar with carbon reinforced ends for increased breaking strength. The blade area is 559 cm²

Length:
210 – 240 cm
increasing 10 cm

Weigh:
0,94 kg
(subject to size)



TYPE PLD.0 FOR HALIBUT

One-hand paddle
for HALIBUT.

Length:
72 cm



OARS 902.2

Oars to the ALFONSO boat.

Length:
190 cm

Weigh:
2 kg



KAYAK PADDLE TYPE 379S.2

New development in our series of kayak paddles: A double paddle on glass laminate spar. The paddle can be adjusted in various angles and length from 230 to 240 cm.

Variable length:
230–240 cm

Weigh:
0,96 kg



ACCESSORIES



Transport drybag
80 l, 100 l, 135 l



Expedition transport
100 l



Drybag for storing equipment
20 l, 40 l, 60 l



Drybag for small items
8 l, 12 l, 20 l



Deck RUSH 1, 2



Deck SEAWAVE for 1 and 2 people



Spray skirt RUSH, SWING,
SEAWAVE, FRAMURA



Double-action
hand pump 2/4



Double/single-action
hand pump 3,2/6,4



Single-action hand pump
RAFTER 5l



Electrical inflator
BRAVO 230/1000



Additional front deck
THAYA, SOLAR



UV-Tech product for
treatment of inflatable
kayaks and boats



Push-Push valve
(0,2 Bar)



Modified Push-Push
valve reduction



Safety relief valve



Pressure gauge for
"Push-Push" valve



Valve wrench for Push-Push
and overpressure valve
HOBBY/PROFI



GUMOTEX safety throw-bag



Fishing rod holder
BORIKA



Fishing rod holder
CANNON



Repair kit – NITRILON



Adhesive ELASTICK 250 ml



Tracking fin



FRAMURA rudder



SEAWAVE rudder



RUSH rudder

CLOTHES



GUMOTEX paddle jacket

This paddling jacket is great for touring and recreational paddling. The jacket is breathable and waterproof. It is made of soft neoprene, neck and wrist cuffs are adjustable, offering great comfort.



GUMOTEX child jacket

It is made of durable two-layer material. This jacket is designed to keep kids warm during their explorations in the wet condition. Neoprene neck cuff and wrist cuffs are adjustable. The waist can be tightened by easy-to-use rubber cord.



GUMOTEX paddle helmet

Protection helmet for watersports is very light and comfortable. The adjusting system makes the helmet highly universal and it fits almost everyone. This version includes ear protection.



GUMOTEX paddle trousers

Loose fit allows free movement. Neoprene waist is adjustable and protects lower back from cold.



GUMOTEX neoprene trousers

Trousers are made of 3 mm neoprene. They provide good warmth and flexibility during watersports. Thanks to two-way zipper in the front and short zippers on the ankles, is put on and taken off very easily. Exposed areas are protected with PU coating.



Life jacket



Child life jacket



GUMOTEX neoprene shoes

Neoprene shoes protect your feet from cold water and sharp rocks.



GUMOTEX neoprene socks

Neoprene socks are made of 3 mm thick neoprene with abrasion resistant material on the outside. They offer warmth.



BOAT DESCRIPTION



	RUSH 1	RUSH 2	THAYA	SWING 1	SWING 2	TWIST 1	TWIST 2/1	SOLAR	FRAMURA	SEAWAVE
Length	355	420	410	316	402	260	360	410	410	455
Width	81	82	89	87	87	79	83	80	75	83
Air chambers	3+1	3+2	3 + 2 / 4 / 6 + 2	3	3	3 + 2	3 + 3	3 + 2 + 2	3 + 1 + 1	3 + 3 + 2
Max. operation pressure	0,025/0,25/3,75 0,05/0,5/7,2	0,025/0,25/3,75 0,05/0,5/7,2	0,02/0,2/3,0 0,05/0,5/7,2	0,02/0,2/3,0	0,02/0,2/3,0	0,02/0,2/3,0	0,02/0,2/3,0	0,02/0,2/3,0	0,02/0,2/3,0	0,025/0,25/3,7
Packed dimensions	65 x 40 x 28	69 x 48 x 28	63 x 40 x 26	64 x 42 x 24	67 x 42 x 30	53 x 35 x 19	53 x 36 x 20	54 x 39 x 24	68 x 40 x 30	68 x 43 x 30
Weigh	12	15,5	17,5	11,3	14,3	9	13	16	16	17,5
Max. load	150	195	230	120	220	100	180	270	180	250
Max. number of persons	1	2	2 + 1	1	2	1	2	2 + 1	1	3
Material	NITRILON®	NITRILON®	NITRILON®	NITRILON®, PES, PUR	NITRILON®, PES, PUR	NITRILON®	NITRILON®	NITRILON®	NITRILON®, PES, PUR	NITRILON®
Colour	6 11C	6 11C	5C 11C	5C 11C 1C 11C	5C 11C 1C 11C	5C 11C 1C 11C	5C 11C 1C 11C	5C 11C 1C 11C	5C 11C	5C 11C
Difficulty	Gr. 2	Gr. 2	Gr. 2	Gr. 2	Gr. 2	Gr. 1	Gr. 1	Gr. 2	Gr. 1	Gr. 2
Accessories	Tracking fin, Transport drybag 100l, Repair kit Valve wrench for Push-Push and overpressure valve	Tracking fin, Transport drybag 100l, Repair kit Valve wrench for Push-Push and overpressure valve	Tracking fin, Transport drybag 100l, Repair kit Valve wrench for Push-Push and overpressure valve	Tracking fin, Transport bag made from textile, Repair kit Valve wrench for Push-Push and overpressure	Tracking fin, Transport bag made from textile, Repair kit Valve wrench for Push-Push and overpressure	Tracking fin, Transport bag made from textile, Repair kit Valve wrench for Push-Push and overpressure	Tracking fin, Transport drybag 80 l, Repair kit Valve wrench for Push-Push and overpressure valve	Tracking fin, Transport drybag 100 l, Repair kit, Valve wrench for Push-Push and overpressure valve	Tracking fin, Transport drybag 100 l, Repair kit, Valve wrench for Push-Push and overpressure valve	Tracking fin, Transport drybag 100 l, Repair kit, Valve wrench for Push-Push and overpressure valve
Recommended accessories	Paddle type 719S.2 GTX hand pump 2/4 Cockpit RUSH 1 and RUSH 2 Drybag for small items 8l, 12l, 20l RUSH rudder	Paddle type 719S.2 GTX hand pump 2/4 Additional front deck Drop-stitch seat THAYA Drybag for small items	Kayak paddle type 719S.2 GTX hand pump 2/4 Additional front deck Drop-stitch seat THAYA Drybag for small items	Spray skirt Kayak paddle type 702 asymmetric GTX hand pump 2/4 Transport drybag 100 l Drybag for small items	Spray skirt Kayak paddle type 702 asymmetric GTX hand pump 2/4 Transport drybag 100 l Drybag for small items	Kayak paddle type 702 asymmetric GTX hand pump 2/4 Drybag for small items	Kayak paddle type 702 asymmetric GTX hand pump 2/4 Seat SOLAR Drybag for small items Additional front deck	Spray skirt Paddle type 703.2 sea GTX hand pump 3,2/6,4 FRAMURA rudder Drybag for storing equipment	Spray skirt Paddle type 719S.2 GTX hand pump 3,2/6,4 Seat SEAWAVE SEAWAVE cockpit for 1 or 2 persons SEAWAVE rudder Drybag for storing equipment	

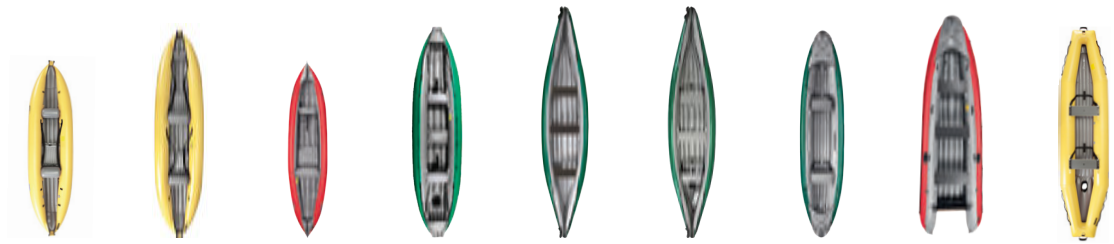

	K1	K2	SAFARI 330	BARAKA	SCOUT ECONOMY	SCOUT STANDARD	PALAVA	RUBY XL	ORINOCO
Lenght	340	390	330	410	445	445	400	430	405
Width	98	100	80	105	95	95	94	125	105
Air chambers	3 + 2 + 1	3 + 2 + 3	3 + 1 + 2	3 + 1	3	3	3	3	3
Max. operation pressure	0,025/0,25/3,7	0,025/0,25/3,7	0,02/0,2/3,0	0,02/0,2/3,0	0,02/0,2/3,0	0,02/0,2/3,0	0,02/0,2/3,0	0,02/0,2/3,0	0,025/0,25/3,7
Packed dimensions	70 × 45 × 28	70 × 45 × 30	53 × 38 × 24	70 × 43 × 30	70 × 45 × 30	70 × 45 × 30	60 × 40 × 25	68 × 51 × 29	70 × 53 × 32
Weigh	15	20	12	23,5	24,5	25	17,5	29	25,5
Max. load	100	200	130	350	450	450	240	410	350
Max. number of persons	1	2	1	2 + 1	3 (2 + 2)	3 (2 + 2)	2 + 1	3	2
Material	NITRILON® DS	NITRILON® DS	NITRILON®	NITRILON®	NITRILON®	NITRILON®	NITRILON®	NITRILON®	NITRILON® DS
Colour									
Difficulty	Gr.4	Gr.4	Gr.3	Gr.4	Gr.3	Gr.3	Gr.3	Gr.2	Gr.4
Accessories	Transport drybag 100 l, Repair kit Valve wrench for Push-Push and overpressure valve	Transport drybag 135 l, Repair kit Valve wrench for Push-Push and overpressure valve	Tracking fin, Transport drybag 80 l, Repair kit Valve wrench for Push-Push and overpressure valve	Transport drybag 135 l, Repair kit Valve wrench for Push-Push and overpressure valve	Transport bag, Repair kit Valve wrench for Push-Push and overpressure valve	Transport drybag 135 l, Repair kit Valve wrench for Push-Push and overpressure valve	Transport drybag 100 l, Repair kit Valve wrench for Push-Push and overpressure valve	Transport drybag 135 l, Repair kit Valve wrench for Push-Push and overpressure valve	Transport drybag 135 l, Repair kit Valve wrench for Push-Push and overpressure valve
Recommended accessories	Kayak paddle type 702 asymmetric GTX hand pump 3,2/6,4 Drybag for storing equipment GUMOTEX safety throw-bag		Kayak paddle type 702 asymmetric GTX hand pump 2/4 Drybag for storing equipment	Canoe paddle type 505 allround GTX hand pump 3,2/6,4 Drybag for storing equipment GUMOTEX safety throw-bag	Canoe paddle type 505 allround GTX hand pump 3,2/6,4 Drybag for storing equipment GUMOTEX safety throw-bag		Canoe paddle type 505 allround GTX hand pump 3,2/6,4 Seat PALAVA Drybag for storing equipment	Oars 902.2 Canoe paddle type 505 allround GTX hand pump 3,2/6,4 Electric or combustion engine Drybag for storing equipment	Canoe paddle type 505 allround GTX hand pump 3,2/6,4 Drybag for storing equipment GUMOTEX safety throw-bag

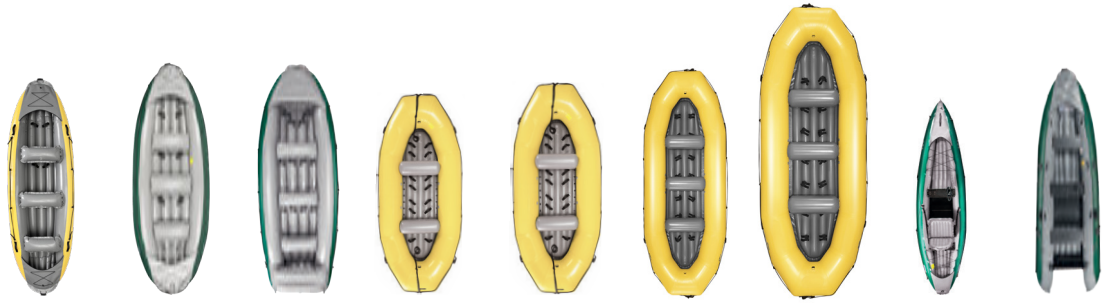

	ONTARIO 420	ONTARIO 450 S	COLO- RADO 450	PULSAR 380N	PULSAR 420 N	PULSAR 450 N	PULSAR 560 N	HALIBUT	ALFONSO
Length	420	450	450	380	420	450	560	375	430
Width	145	157	160	178	190	210	210	96	125
Air chambers	3 + 3	3 + 3	3 + 5	5 + 2	5 + 2	5 + 3	5 + 3	3 + 1	3
Max. operation pressure	0,02/0,2/3,0	0,02/0,2/3,0	0,02/0,2/3,0	0,025/0,25/3,7	0,025/0,25/3,7	0,025/0,25/3,7	0,025/0,25/3,7	0,02/0,2/3,0	0,02/0,2/3,0
Packed dimensions	67 × 55 × 33	67 × 58 × 30	68 × 55 × 31	80 × 65 × 40	85 × 65 × 40	90 × 70 × 35	100 × 70 × 50	70 × 46 × 30	68 × 55 × 30
Weigh	29	30	37,5	44	50	60	75	21	32,7
Max. load	600	630	600	650	800	900	920	200	410
Max. number of persons	6	6	6	7	8	9	12	1	3
Material	NITRILON®	NITRILON®	NITRILON®	NITRILON® DS, NITRILON® Extra	NITRILON® DS, NITRILON® Extra	NITRILON® DS, NITRILON® Extra	NITRILON® DS, NITRILON® Extra	NITRILON®	NITRILON®
Colour									
Difficulty	Gr.3	Gr.3	Gr.4	Gr.5	Gr.5	Gr.5	Gr.4	Gr.1	Gr.2
Accessories	Transport bag, Repair kit Valve wrench for Push-Push and overpressure valve		Transport bag, Repair kit Valve wrench for Push- Push and overpressure valve	Transport bag, Repair kit Valve wrench for Push-Push and overpressure valve				Tracking fin, Transport drybag 100 l, Repair kit Valve wrench for Push- Push and overpressure valve	Transport drybag 135 l, Repair kit Valve wrench for Push- Push and overpressure valve
Recommended accessories	Canoe paddle type 505 allround GTX hand pump 3,2/6,4 Drybag for storing equipment		Canoe paddle type 505 allround GTX hand pump 3,2/6,4 Drybag for storing equipment GUMOTEX safety throw-bag	Canoe paddle type 504 raftguide Single-action hand pump RAFTER 5l Abrasion resistant foil Drybag for storing equipment GUMOTEX safety throw-bag				Canoe paddle type 504 raftguide Single-action hand pump RAFTER 5l Abrasion resistant foil Drybag for storing equipment GUMOTEX safety throw-bag	Canoe paddle type 505 allround Oars 902.2 GTX hand pump 3,2/6,4 Electric or combustion engine Drybag for storing equipment



GENTLE TO NATURE
FRIENDLY TO PADDLERS



GUMOTEX Coating, s.r.o.
Mládežnická 3062/3a
690 02 Břeclav
Czech Republic

Phone: +420 519 314 111
E-mail: BoatsAndOutdoor@gumotex.cz
www.gumotexcluny.cz