





# 60 YEARS PRIJON











## KEY

### SPECIFICATIONS

-  Weight of kayak
-  Volume of kayak
-  Paddler's weight
-  Capacity (paddler + gear)



### CHARACTERISTICS

-  Paddling characteristics with raised skeg
-  Paddling characteristics with lowered skeg
-  Directional stability
-  Maneuverability
-  Stability
-  Resurfacing
-  Velocity

## TABLE OF CONTENTS

### COMPANY PROFILE 4

#### INFORMATIONS

Kayak-finder	8
Classification of kayaks according to application	9
Paddle-finder	40
Kajak-Schulen	56
Data directory of kayaks	58
Materials & Warranty	60

#### STORIES

Adventure in Albania	10
----------------------	----

#### PRODUCTS

Whitewater kayaks	12
Whitewater equipment	17
Fast single seaters	20
Allrounders	28
Double seaters	16/31/34-35/37
Beginner kayaks	36
Kids equipment	38
Paddles	41
Neoprene clothing	44
Spraydecks & Cockpit covers	46
Waterproof packaging	48
Accessories	50
Boat carts	52
Transport systems	54





**1987**  
*Toni jun. during a  
race in Merano*

# 60 YEARS PRIJON

## PRIJON KAYAKS - MADE WITH PASSION IN GERMANY SINCE 1962.

Since the formation of the Prijon GmbH we place importance to sustainability, respect of humans and nature and a fair treatment of our partners. Being responsible for what we do isn't a trend for us, but has ever been an obviousness instead. Our wish to spend time on the water with a good feeling in the heart, spurs us to pollute the nature as less as possible. With the Alps in view and the Chiemsee lake in reach we see a huge responsibility for sustainable thinking and acting.

### A childhood dream becomes reality

What's easy to realize for paddlers these days, has been hard pioneering decades ago. The way to Prijon becoming a world known term for kayak sport is an example for continuous development. In 1946 Anton Prijon sen. began to write history in the kayak sport. He manufactured his first ever kayak in Slovenia, won his first races in his selfmade kayak and continued making racing kayaks, folding kayaks and paddles until he moved to Germany in 1957. Back then, Anton Prijon was the best kayaker in the world, an exceptionally gifted constructor of kayaks and tinkerer.

He became famous for his wins at the German and world championships 1958 and 1959. During these days also the first tries of making kayaks out of Polyester took place. Toni Prijon sen. took this chance to realize his own ideas and to manufacture his desired kayaks. In 1962 he founded his sport workshop in Rosenheim together with his wife Lotte. This advantageous combination of being a manufacturer of kayaks and competitive sportsman in the same person was the successful basis for creative peak performances.

When the Taifun was introduced to the market in 1982, it was the first ever blowmolded HTP kayak and sparked off a revolution in the kayak sport. This new material raised the limit again for a long time. The Taifun set new benchmarks in whitewater.

Toni Prijon sen. passed his love for watersports to his children and grandchildren and meanwhile, the small craft business for paddles became a world known manufacturing for kayaks, now led by Toni Prijon jun. To bring it out: a production of kayak in Germany can only persist by offering excellent quality. That's why all of our kayaks are manufactured by hand without piecework. A lot of you Prijon paddlers already know it, all the others are invited to test us. Because you can feel our enthusiasm and commitment when sitting in a Prijon kayak. Most of our products are "Made in Germany" and all of our kayaks are manufactured by hand without piece-work. This seal of quality and our way of how to produce our products has now, in the days of pandemics and raising globalization, more worth than ever before. It stands not only for the quality of a product, but also for securing local jobs and protection of the environment.

We're looking forward to the next 60 years together with you!



**1960**  
*Short trip Kayak Club  
Rosenheim*



**1985**  
*Northwest Territories Toni sen.*



**1987**  
*Kayak Club Rosenheim  
honoration for World Champ title*



**1960**  
*German Championships  
Ammer Toni sen.*



**1957**  
*Workshop in  
Slovenia*



**1987**  
*Kayak Club Rosenheim  
honoration for World Champ title*





## HAND MADE IN BAVARIA

*Nature-loving • eco-friendly • sustainable*

Bavaria is our homeland, craft is our tradition. A family environment, long-term friendships and collaborations with our partners and customers are important for us. We stand for sustainable thinking and doing and we care about the environment, in which we love to be outdoors in nature.

**Short ways:** More than 80% of the components assembled in our kayaks, come from our own factory or from suppliers located within max. 300km radius. This ensures only short delivery- and transport routes to our dealers and customers. And this results in only low emissions and low energy costs for the delivery. The heavy oil consuming containership is missing in the life cycle assessment of a Prijon kayak!

**We sew and press on our own:** All of our sewed and pressed parts come from our workers in our own sewing room or compactor. This is how we work regional and sustainable.

**Inhouse energy generation:** Since 2009 we operate a photovoltaic-system on the roof of our warehouse and ecologically produce a part of our needed electricity for the production out of sunlight. The process heat of the production of the hulls is used for the heating of the production building.

### Prijon Eco - We love our nature:

Our eco-products are sustainable and eco-friendly. The kayaks are made according to the latest standards in our factory in Rosenheim, Germany. Permanent quality checks during the production guarantee a constant high quality and increase the value chain in the country. Our love to nature and the responsibility for the following generations is a matter of the heart for us. We award the eco-label to all of our products, produced according to these standards.



## PERFECTION & INNOVATION

*From the idea to the finished product*

Our goal is to develop and produce the best possible products for the kayak sport. Under the guidance of canoe-slalom world champion Toni Prijon and with more than 60 years of experience in professional sports and boatbuilding-craft, we manufacture state-of-the-art kayaks, paddles and accessories for the highest demands. Incorporating pioneering trends, advanced technologies and new materials.

When a new idea is born and the first CAD-drawings are made, our modelers make a mold for the manufacturing of a prototype. This prototype is then tested under real conditions in nature. We test and optimize as long until the desired quality of paddling pleasure is reached. Then this new kayak goes into series manufacturing.

We diligently choose the materials for the production of our kayaks and accessories. Only materials perfectly suitable for workmanship, purpose and demands of customers each are in line for this.

Fittings and interior equipment are mounted on all Prijon kayaks by diligent handiwork. We concept and produce a major part of accessories for paddlers by our own or together with suppliers, to fulfill the high quality and functionality demands.

Our robust HTP-kayaks are blowmolded in Rosenheim/Germany. The laminated models are completely made by hand in the traditional way, to get them as stiff and light as possible. Top and bottom of our PriLite kayaks are thermoformed and inextricably glued together.

If a customer has a special wish we try to fulfill it by exhausting all possibilities. Laminated kayaks are available in custom colors.

Innovative ideas, demanding development work, perfect manufacturing and permanent checks guarantee unique kayak experiences for every paddler. Convince yourself and test a Prijon-kayak at one of our numerous dealers.





# KAYAK-FINDER

Which kayak is the right one for me?

We offer touring- and seakayaks, recreational and whitewater kayaks. Our kayak-models are subdivided in four categories, to make the selection easier for you. They are classified according to the shape of the kayak and its purpose. On our website [www.prijon.com](http://www.prijon.com) you will find a more exact and detailed comparison tool. On the pages 58-59 you'll find all data and specifications as well as a classification of the kayaks according to their area of application in an overview.

## FAST SINGLE-SEATERS ~

For lakes, the coast and the sea

These kayaks are slim and long, which makes them fast and track well. Perfect for sporty and ambitious paddlers, for fast trips with or without luggage. You'll find the fast single-seaters from page 20.

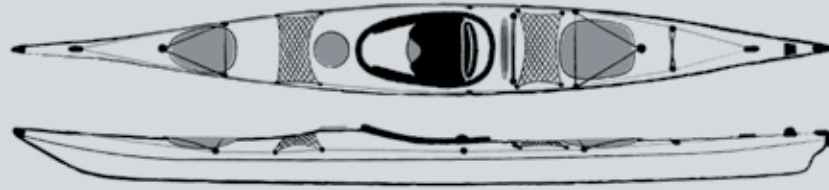

## ALLROUNDERS ~

For rivers, lakes and calm coastal areas

Kayaks for a wide purpose. Established all-rounders for tours with luggage, agile kayaks for moving rivers and various double-seaters. These kayaks offer you a high stability and a good ground Velocity. You'll find our allrounders from page 28.

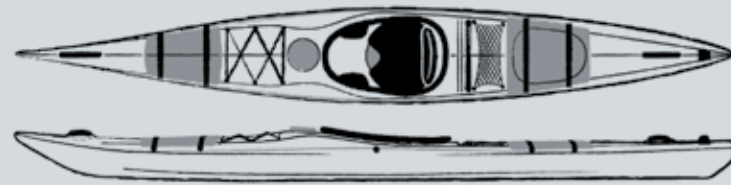

## ENTRY-LEVEL KAYAKS ~

For beginners and casual paddlers

Made for short trips with small luggage and the rental business. Very stable and neutral to paddle, these boats are very easy to get along with. They track well, are easy to maneuver and are offered at an attractive entry-level price. You'll find the entry-level kayaks from page 36.



## WHITewater KAYAKS ~

For extreme trips in rivers

Short and very agile kayaks with a heavy rocker, for easy to heavy whitewater. Equipped with a special whitewater seat-system and nearly indestructible hull made of HTP. You'll find whitewater kayaks from page 12.

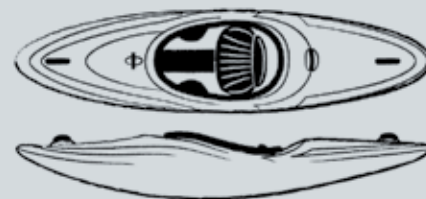

## CLASSIFICATION OF KAYAKS ACCORDING TO THEIR APPLICATION

	WW 3+	WW 2 - 1	SMALL RIVER	LARGE RIVER	LAKE	COAST & SEA
<b>FAST SINGLE-SEATERS</b>						
Seatron GT						
Seayak Classic HTP						
Seayak 500LV HTP						
Seayak Junior Pro HTP						
Aruna PriLite						
Grizzly HTP						
Marlin Prilite						
Marlin Prilite LV						
<b>LAMINATED SINGLE-SEATERS</b>						
Neptun						
Falcon						
Barracuda RS						
Marlin LV Laminat						
Millenium Evo						
Proteus						
<b>ALLROUNDERS</b>						
Enduro 450 HTP						
Enduro 380 HTP						
Touryak 500 HTP						
Touryak 470LV HTP						
Dayliner L HTP						
Dayliner S HTP						
Narva Prilite						
Prilite Vellamo						
Munga HTP						
<b>DOUBLE-SEATERS</b>						
Excursion Evo HTP						
Poseidon HTP						
Dayliner Duo						
Piave						
Yukon KII Sport						
Yukon KII Relax						
<b>CUSTOM LINE</b>						
Customline 370 HTP						
Customline 430 HTP						
Customline 470 Relax HTP						
Customline 490 HTP						
<b>WHITewater KAYAKS</b>						
Pike						
Cocaine						
Curve 2.5 HTP						
Curve 3.0 HTP						
Curve Creek 3.5 HTP						
2B						



Text: Jobst Hahn  
Photos: Michael Neumann

VALBONA - LOVE AT FIRST SIGHT

# ADVENTURE IN ALBANIA



Freezing cold in the Alps, seas of blossoms and powerful sunlight in the south. Spring is two-faced in Europe. We're on the way to the Tara-gorge at the moment and wanted to pop in the Valbona valley when passing, to visit a friend. The Valbona is the left tributary of the Drin, also called the "Soča of Albania". We turned into the valley with certain expectations - and the river exceeded all of them. It was love at first sight! Adieu Tara-gorge - we'll stay three days to explore this river here! The Valbona has its source in the Albanian Alps in the same-named National park and offers you all types of whitewater - from tricky class 3 - 4 (5) on the upper course, to open and easy class 1 - 3 on the lower course - until it flows into the Koman reservoir. Paddlers knowing and loving the Soča will immediately feel comfortable on the Valbona!

THE WONDERFUL  
VALBONA IS CALLED THE  
ALBANIAN SOČA WITH  
GOOD REASON.







## PIKE

PRO: #101660  
SPORT: #101663

The new benchmark for riverplay kayaks! It's fast and agile and combines the paddling dynamics of a riverrunner with the safety of a creeker. It accelerates rapidly, reaches speed with just a few strokes, can be paddled on a line and or quickly and super-simple turned on the spot. In, through and out of eddies, surfing and carving becomes a real pleasure with it. The flat bottom impresses with a lot of guidance and speed and follows precisely every stroke. You can smoothly add eddies and waves to your line. Plus: The flat stern invites you to play on all occasions and can easily be undercut. The bow offers a heavy rocker, safety and volume for wild water. When things get rough, the new PIKE always stays on top and dry!

20 kg (Pro) 18 kg (Sport)	250 L	60 - 90 kg

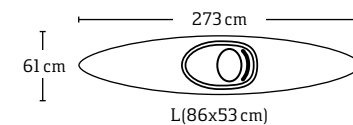

		<b>MADE WITH PASSION IN GERMANY.</b>



## COCAINE

PRO: #101650  
SPORT: #101653

You want to paddle fast in whitewater? You want to sit in an agile kayak? Then the Cocaine is the right one for you! It will make you paddle ridiculously fast and after one paddle you will be addicted to paddling it. Its length of 275 cm and its long waterline make it fast, the flat bottom offers excellent agility when needed. Shaped for paddlers looking for a fast whitewater kayak and for participants in boatercross races.

22 kg (Pro) 20 kg (Sport)	305 L	65 - 95 kg

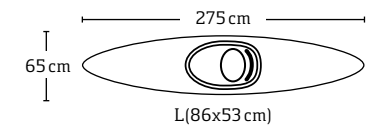

		<b>MADE WITH PASSION IN GERMANY.</b>



# CURVE

Our established CURVE range offers kayaks for all types of whitewater. They have pronounced edges on the bottom for a high stability and a maximum of agility. The CURVE reacts fast on hip movements, gives you direct feedback and enables you to paddle precisely. Therefore it is fun both for pros and beginners.

We offer all of our whitewater kayaks in two versions:

## PRO-OUTFITTING

Fully padded PRO seat-system with seat-pad, hip pads and backbelt with ratchet system | 3-D thigh braces with large, ergonomically formed knee pads | Bottom rail with foam pillars in front and rear for maximum stiffness + throw bag fixation | Several bars and handles on top | Aluminum bulkhead footrest

## SPORT-OUTFITTING

Seat-system with seat-pad, hip pads and backbelt with ratchet system | 3-D thigh braces with foam pads | Several bars and handles on top | Aluminum bulkhead footrest



> Picture shows Sport-Version



## CURVE 2.5 HTP

PRO: #101620  
SPORT: #101623

Nippy and very agile riverrunner for smaller and lighter paddlers. Its low weight and the smaller measurements simplify its handling. The backwards extended cockpit extends the room to move. Safety is offered by the wide tip, the high rocker profile makes surfing waves easy.

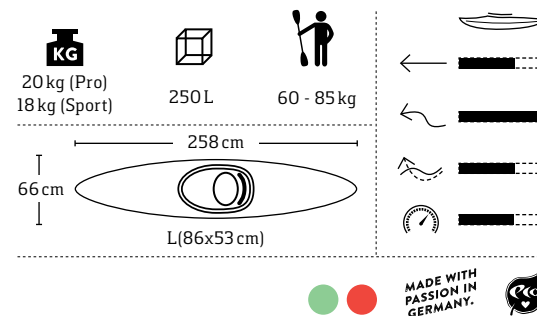

## CURVE 3.0 HTP

PRO: #101600  
SPORT: #101603

The allrounder! Doesn't matter if you want to paddle easy or heavy whitewater, small or steep creeks - this kayak is agile, runs fast and precisely in an out of eddies and its flattened stern invites you to stern squirt at every occasion. Catch the next wave and surf it with the Curve 3.0!

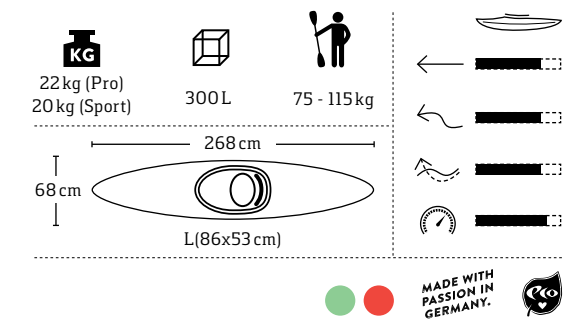

## CURVE CREEK 3.5 HTP

PRO: #101630  
SPORT: #101633

Fast and agile creeker made for medium to heavy whitewater. Its high volume in the bow and stern offers a lot of safety and guarantees its excellent resurfacing qualities. The tip always stays on top of the waves.

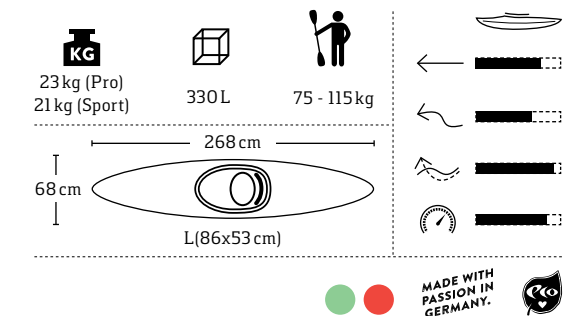





2B



**2B #102010**

It doesn't matter if you want to explore whitewater with your best friend, family or an inexperienced paddler - with this whitewater tandem paddling is double the fun! In heavy whitewater two experienced kayakers can show their skills, while kayak schools and rental stations are another ideal terrain for the 2B. The flat bottom, combined with the firm edges and the heavy rocker, guarantee its stability in whitewater. It's very easy to maneuver.

The 2B offers you unprecedented paddling enjoyment! A light double-seater with the paddling characteristics of a modern whitewater kayak. Our individually adjustable PRO-outfitting offers you padded seats and thigh braces, aluminum bulkhead footrests in front and rear guarantee maximum comfort and safety. A new way to paddle whitewater in twos!

37kg   
 540L   
 190kg (gesamt)

372cm  
 69cm  
 L(86x51cm)

  
 MADE WITH PASSION IN GERMANY.   

**2B KIDS-SEAT SET #1000047**

Paddling like the adults! The separately available child seat consists of a foam cushion for the seat and the footplate. It enables your child to sit in a raised position and offers maximum comfort due to the reduced size of the seat and the shortened distance to the footplate. With this help, your child can see, paddle, and also be above the waves that come over the deck. The seat cushion is racked on the PRO-seat, the cushion of the footplate is racked on the footrest.



**SAVA Length: WW**

Superlight and robust whitewater paddle with a pleasant handling. Immediately offers pressure when putting the blade in the water and enables you to powerful strokes. The midrib on the front side guides the blade stably through the water, while the rib with foam core on the rear side provides outstanding stiffness.

SAVA Carbon	#379000	SAVA GRP   red	#377000
SAVA Carbon ERGO	#379000E	SAVA GRP   yellow	#378000



**KAPPA MEN | KAPPA WMN Length: WW**

Whitewater paddle with an increased blade to shaft offset. This blade forward design gives you a more powerful catch. Ultimate performance and a best possible power transmission is offered by the stiff blades with foam core. Two Blade sizes available to fit every whitewater paddler. Available in Glassfiber (2 colors) and carbon.

KAPPA MEN Carbon	#347000	KAPPA WMN Carbon	#369000
KAPPA MEN Carbon ERGO	#347000E	KAPPA WMN Carbon ERGO	#369000E
KAPPA MEN GRP   red	#348000	KAPPA WMN GRP   red	#367000
KAPPA MEN GRP   yellow	#349000	KAPPA WMN GRP   yellow	#368000



**RIM KINETIC Length: K**

Robust and economically priced allround paddle. Works as a training paddle for whitewater paddlers or those wishing to become one as well as with crossover kayaks! Blades made of sturdy RIM material, shaft made of aluminum with soft coated handles.

RIM Kinetic	#316000
-------------	---------







# WHITewater EQUIPMENT



## CURVE-LINE

Whitewater PFD with integrated safety strap-system. Two big front bags and a lot of mounting possibilities. Normed according to CE.

Sizes: S | M/L | XL/XXL  
#80090



## PRO SAFE

Functional whitewater spray deck with pre-formed plate and Latex-coating on the inside for maximum grip on the rim. Knee belt and grip sling as standard feature.

WAIST SIZES: 72 | 79 | 86 | 93 cm  
#73900



## THROWBAG ALLROUND

20m rope, belt loops at the sides and perimeter strap with a lock for quickly attaching it to the equipment when climbing or to secure it in the kayak.

#80325



## RESCUE SYSTEM

Versatile life-saving equipment for the use in whitewater, including paddle-carabiner. To be attached on your PFD.

#80190



## HELMET KUPA

Optimized protection for whitewater paddling! Superlight polycarbonate-shell - the helmet weighs only 320 g. A turn dial makes it easily and steplessly adjustable from 54 to 61 cm. It comes with two, nonadsorbing different sized foam pad-dings. Normed according to CE EN 1385.

Size: 54 - 61 cm  
Helmet KUPA | green #55400  
Helmet KUPA | orange #50400

## HELMET SURF

Helmet made of ABS-plastic shell, offering a high level of rigidity, and a shock-absorbent Poly-propylene hard foam interior. Spin-Disk-System for a continuously ad-justable head girth. Available as Full cut with ear-pre-tection or Shortcut.

Size: 51 - 63 cm  
Helmet SURF #50110  
Helmet Surf SHORT CUT yellow #52160



## ROPE ROLL

For building a hoist in dangerous situations in whitewater to rescue other paddlers.

#80180



## CARABINER

For rescuing and securing of pad-dlers, boats and equipment. The large opening fits around the paddle shaft.

#80410



## NOSE CLIP

Essential for every whitewater kayaker! Stainless steel spring clip, rubber pads and cord. Protects your nose from water ingress.

#90185



## FLOATERS

Prevent your kayak from filling with water after emergency exits and provide extra stiffness for the boat.

Floaters come per item (if not otherwise mentioned). Available in two versions. Sizes as in table.

SIZE / MODELL	PVC blau	NYLON rot
1 / Front (each) for Wizard, Athlete, F 262	#60303	#60403
2 / Front (each) for Pike, Cocaine, every Curve, every Pure, Forte, 2B, Munga	#60301	#60401
3 / Front (each) for Tornado, Taifun	#60305	#60405
4 / Rear (each) for every Curve Active/Sport, Forte Active, every Pure Active, Wizard	#60304	#60404
5 / Rear (each) for Chopper, Cross	#60302	#60402
6 / Rear (each) for Tornado, Taifun	#60306	#60406
7 / Rear (each) for Pike, Athlete	#60308	#60408
10 / Rear (each) for Cocaine PRO, Curve 2.5 PRO, Curve 3.0 Pro, Curve Creek PRO	#60315	#60415
11 / Rear (each) for 2B	#60310	#60409
AIR-Pack Floaters Nylon with bag for Whitewater kayaks		
Floaters for canoes 3,2 m (Pair)	#60207	



# SEATRON GT



A kayak for the medium to larger paddler looking for a durable quality performance seakayak for short and long tours that can handle rough conditions and paddle effortlessly on calmer days. Made primarily for extensive open water crossings, surfing waves and long multiday trips with all you need. The SEATRON GT has a high stability combined with a high maneuverability, especially during rough conditions at sea. Its modern shaped, progressive hull with a medium rocker profile enables you to either paddle fast and straight or move the kayak on the edge by using your weight and paddle technique. It surfs well with following waves as you paddle and is effortless to control.

The SEATRON GT keeps its excellent characteristics also when fully loaded for multiday trips. Larger paddlers will love the well-spaced foot space / leg room and the comfort from all the finer details made in this kayak. Volume is increased in the front of the kayak for better lift over waves giving a dryer ride into the wind. Hatches are the larger type with neoprene with plastic protective covers fixed in place with easy to use elastic lines. The day hatch forward of the cockpit is in easy reach.

For this kayak there's an optional 4th day hatch behind the cockpit available at a premium or as a DIY retrofit kit (Art.Nr. 10000089).



## SEATRON GT #100490



An optional third bulkhead with day hatch behind the cockpit is available at a premium. #10000090

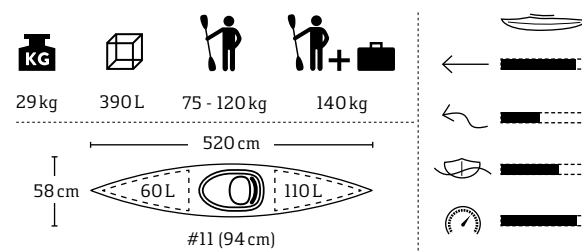

# SEAYAK

Fast and safe kayaks, easy to handle on the water. Made for multiday trips with luggage, on large rivers and open waters. They offer a very high directional stability, are easy to paddle around corners by using your weight and they're reliably stable in inclinational positions.



## SEAYAK CLASSIC HTP #100430

Agile allrounder for medium weight and sized paddlers. It offers comfortable space conditions and enough storage for extensive trips on rivers and open waters. A high Velocity is guaranteed by its longish and slim shape. The classic knickspant-construction makes it tracking well and easy to maneuver on the edges.

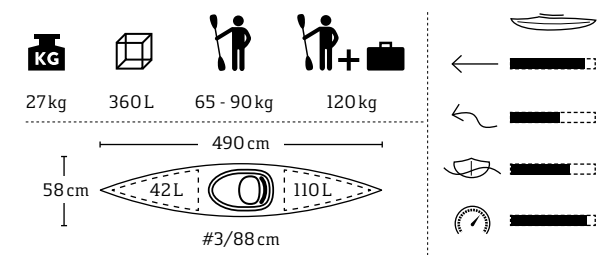

## SEAYAK 500LV HTP #100440

Sporty, fast and directional stable kayak. Its low overall volume as well as a low cockpit offer an optimum seating position for smaller and lighter paddlers. Easy to paddle by using your weight.

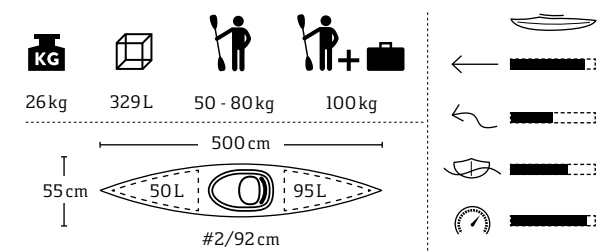



# ARUNA & NEPTUN

Modern shaped, skeg-type seakayaks. Their heavy rocker makes them easy to surf and paddle. They also work on multi-day trips and open water expeditions. The spring loaded skeg system makes them well-tracking, while the comfortable seat system offers optimized contact and control, also in high waves.



## ARUNA PRILITE #20190

Lightweight, fast and agile skeg type sea kayak that will suit the small to medium large paddler looking for a technical kayak to use on longer tours. Easy to manoeuvre using your weight and paddle strokes and incredible fun to paddle and surf. Designed for open water expeditions but equally suited to day trips on lakes and large rivers.

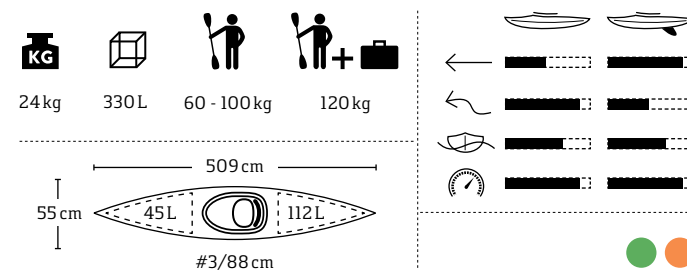

## NEPTUN

GRP: #20212  
CARBON-ARAMID: #20214

Fast and maneuverable sea kayak that will suit the medium to large paddler. Its heavy rocker makes the Neptun very agile on the edge, e.g. when surfing waves. Thanks to the slim shape of the hull it's both tracking well and incredible fast.



Abbildung zeigt mögliche Sonderfarbe



## GRIZZLY HTP #100410

Fast, safe and a great load carrier. Made for long trips with a lot of luggage. It's tracking well and agile on the edges. The GRIZZLY offers a lot of volume, a huge storage space and a very spacious cockpit, which is comfortable especially for taller paddlers. The high volume is also a further safety aspect when touring at sea. A spacious kayak for long trips or big paddlers!

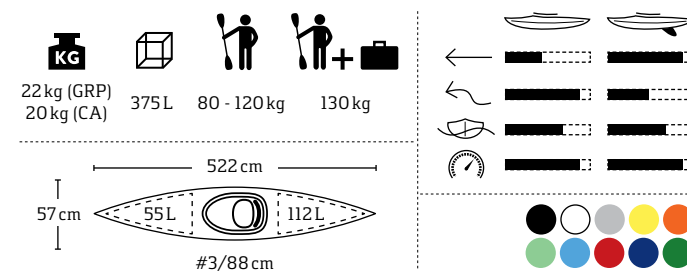
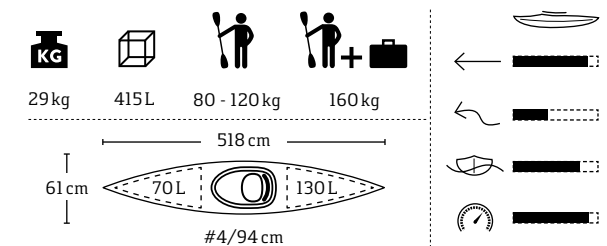

MADE WITH PASSION IN GERMANY.



# MARLIN



## MARLIN

It's elegant, stretched lines make it an ideal boat for travelling. Safe forward gliding, fast changes in direction by using your weight and the edges of the boat, everything can be done in a safe and precise manner. Flat angles on the lateral areas make the boat easy manageable and provide optimum stability. PriLite is a robust, thermoformed ABS-material. Solid, light and tough. Both of the Marlin sizes harmonize excellent as partner-kayaks. The metallic effect of the colored decks is a real eyecatcher!



### MARLIN PRILITE #20140

Medium to high weight paddlers choose the Marlin. An increased leg room and a higher volume in the bow guarantee a comfortable sitting position, also on longer trips.

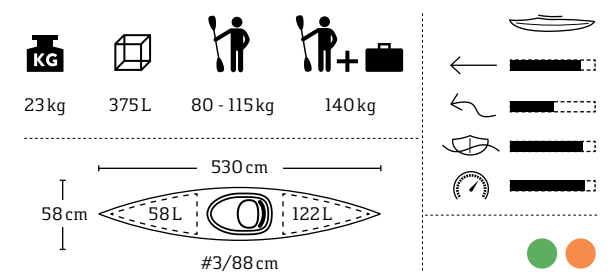

### MARLIN PRILITE LV #20150

Small to midsize and low to medium weight paddlers will love the Marlin LV. Thanks to its lower overall volume and the lower cockpit it offers an optimum sitting position. Very low overall weight due to the PriLite hull.

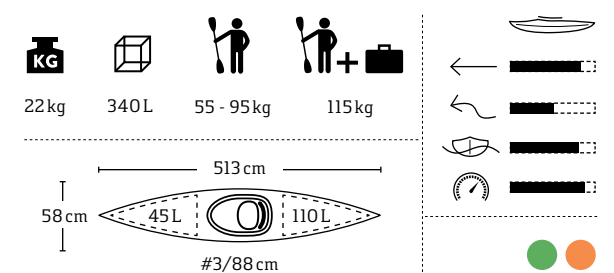



# LAMINATED SINGLE-SEATERS – FAST & LIGHT

Fast single seater kayaks for lakes, the coast and the sea. The shape of these boats is slim and long, which provides them with a high velocity and excellent tracking qualities. Hand-made of high quality glass- and carbon-aramid fibers for maximum stiffness and the lowest possible weight.

Laminated kayaks are available in standard or customized colors. More info on our website. All product pictures show possible custom color combinations. The laminated single seater "NEPTUN" is shown on page 22.



## MARLIN LV LAMINATED

GRP: #20512  
CARBON-ARAMID: #20513

Even lighter, hand-laminated version of the Marlin LV. A very light and stiff kayak with safe and exact handling, for tours with luggage on rivers, lakes and the coast.

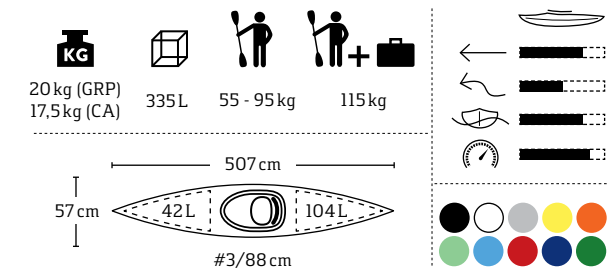

## FALCON

GRP: #20472  
CARBON-ARAMID: #20474

A fast fitness kayak for sporty and ambitious paddlers. Made for a morning workout on the lake, an after work lap or a fast session in between. Agile on the edge!

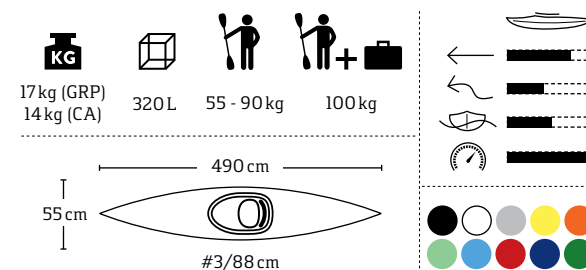

## BARRACUDA RS

GRP: #20802  
CARBON-ARAMID: #20804

A very fast kayak for sporty and ambitious paddlers. Made for racing marathons and long-distance competitions, training in the evening and longer tours with a small amount of luggage.

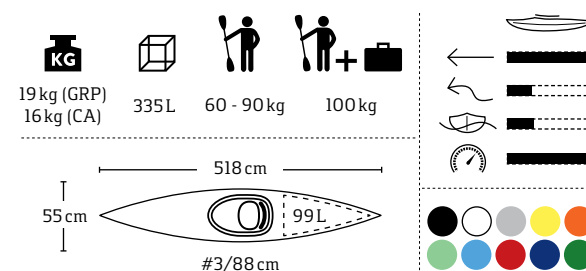

## MILLENNIUM EVO

GRP: #20672  
CARBON-ARAMID: #20674

This beautiful kayak is a combination of a fast seakayak and an agile touringkayak. The long, slim, shape provides a high level of Velocity; the pronounced knickspant on the bottom offers a comparably high measure of agility.

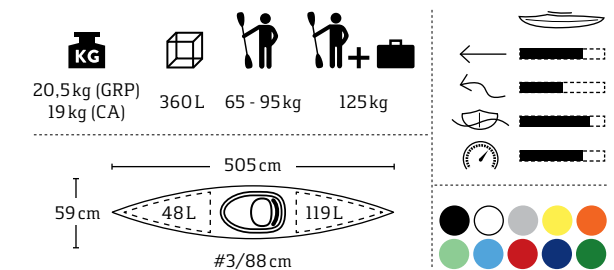

## PROTEUS

GRP: #20292  
CARBON-ARAMID: #20294

Made for long and fast trips on open waters and along the coast. Pronounced keel-sections in the front and rear result in a long water line and consequently in a high cruising Velocity and at the same time superior handling.

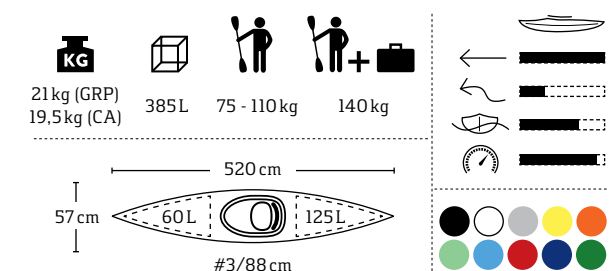



# TOURYAK

The boat for all eventualities! Whether it is a tour on a calm river, a longer round on a big lake or paddling holidays with a lot of luggage, the TOURYAK series is the first choice for all of these. It is large, spacious and safe. The bottom with its dished lateral sides offers a high level of initial and secondary stability, whilst running easily. The established Tour-seat-system allows every paddler to sit in a comfortable position over longer periods of time. Large storage compartments and ample equipment. A true allrounder, made of our almost indestructible HTP.



## TOURYAK 500 HTP #100850

Large, spacious and stable. The spacious cockpit allows even larger paddlers to maintain a comfortable seating position over longer periods of time. Large storage compartments and ample equipment enable you to multiday trips, paddling holidays and expeditions.

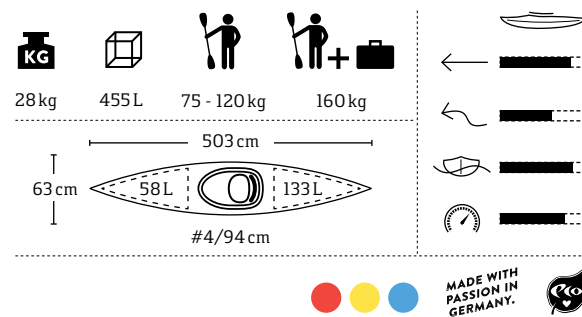

## TOURYAK 470 LV HTP #100860

The perfect choice for smaller and lighter paddlers until a weight of 85 kg. Deck height, width and volume of this touring kayak are adapted to the needs of smaller paddlers.

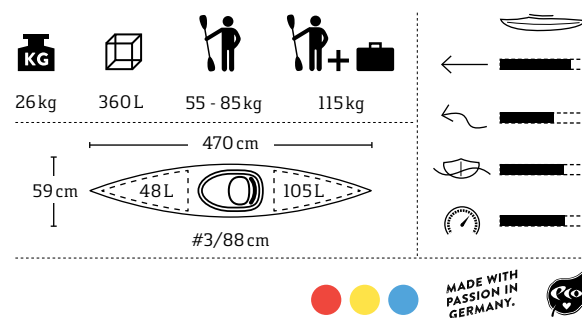

# ENDURO

The adventure starts here! A relaxed tour on the lake, a sporty paddling adventure on a river or action in whitewater - the ENDURO series combines excellent paddling qualities with unbeatable allround skills. Optimized ergonomics are guaranteed by the Tour-seat system and backrest, plus the 3-D-thigh braces. Offering you the best possible comfort and a perfect hold, both on longer distances with luggage and in whitewater. Two waterproof bulkheads, a day hatch and a bungee deck rigging on deck as well as its preparation for steering under-line the touring capability. Easy to edge, turn and plough through any water.



## ENDURO 450 HTP #100550

Agile all-rounder made for lakes, smaller and larger rivers with moving and flowing waters. It focuses on touring, is very maneuverable, turns easily and reacts really fast. It isn't nervous but fast and tracks well for short to longer distance paddling.

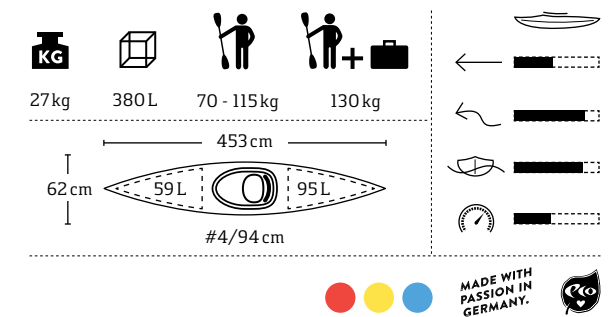

## ENDURO 380 HTP #100560

Short and agile - a true allrounder! Its compact measurements combined with the heavy rocker make it even more agile and fast reacting than the 450. Small lakes, rivers and easy whitewater up to class 2 are his terrain.

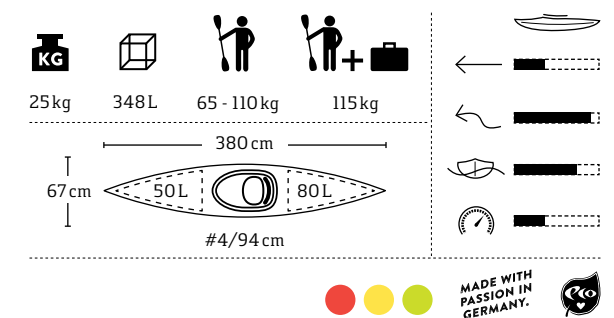



# DAYLINER

Made for beginners and recreational paddlers, looking for uncomplicated paddling fun on daytrips on lakes and rivers. Compact measurements, light weight and an excellent price-performance-ratio are the characteristics of the DAYLINER Series. These kayakers have two watertight separations, a comfortable seating area and can be equipped with a steering. The simple deck equipment saves weight. Pronounced edges on the lower boat provide excellent tracking, the large base in the seating area provides a high level of initial stability and agility.



## DAYLINER S HTP #10180

Smaller and lighter paddlers will feel comfortable in this kayak. Its compact measurements and its low weight make it the perfect choice for women and teenagers.

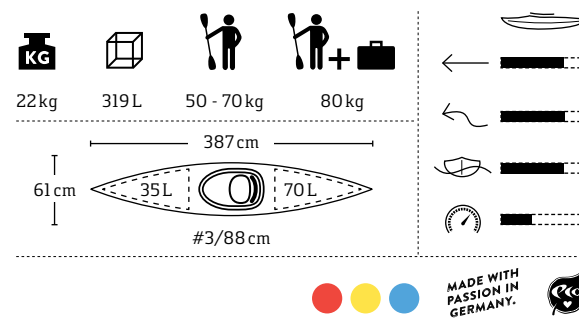

## DAYLINER L HTP #10190

This kayak is designed for medium to large paddlers. Thanks to its length it's tracking well and can carry paddlers up to 105 kg.

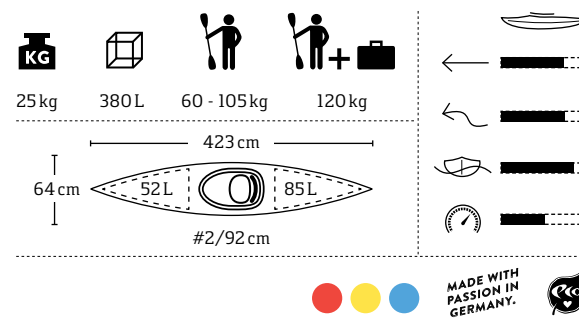

## DAYLINER DUO HTP #100480

Easy gliding, compact double-seater for calm rivers and day trips. Comfortable and uncomplicated characteristics as well as compact measurements guarantee handiness and low weight. Dayliner-specific equipment offers everything you need for pleasant trips at a favorable price.

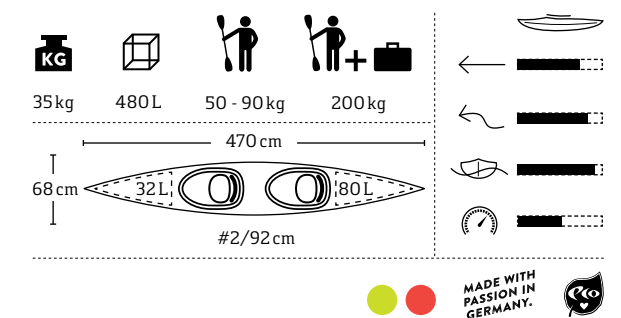



# NARVA & VELLAMO

Lightweight and compact allrounders, made of our established PriLite-material. For calm and slowly flowing waters. They offer you a high initial stability and track well. Thanks to the low weight of the PriLite-material they're easy to handle, e.g. when loading them on and off the car. The NARVA is made for beginners and advanced paddlers, looking for a lightweight and universally - on smaller and larger rivers and lakes - usable kayak. For beginners and recreational paddlers, looking for a compact and light kayak, which is not the fastest and doesn't offer as much volume for gear, but offers a low overall weight and requires only very small space when being stored, the VELLAMO is the right choice.



## NARVA PRILITE #20160

A lightweight, universally usable touring kayak made of our established PriLite-material. This guarantees an easy handling, especially during loading on and off the car. Paddles neutral, tracks well and offers you a high initial and secondary stability. The moderate rocker profile makes it agile.

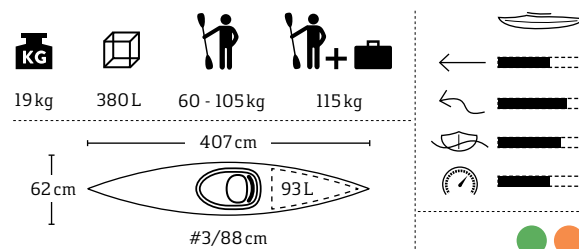

## PRILITE VELLAMO #20165

A superlight, compact and stable recreational kayak for relaxed paddling trips on calm waters. The wide basis and the pronounced edges on the bottom make it stable and thanks to the keel it tracks very well. Its large cockpit makes it very easy to get in and out of the boat. Equipped with a comfortable seat, a watertight rear hatch and an adjustable footrest.

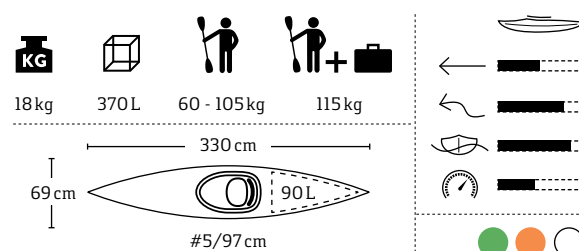

# MUNGA



## MUNGA HTP #101675

Adventure waits for you! Allround and versatile cross-over kayak with skeg! A whitewater-kayak with touring characteristics. Made for a relaxed trip on a lake or whitewater up to class 3. In whitewater, the Munga is very agile, fast and easy to paddle. On calm waters the skeg can be used to make the kayak well-tracking.

It's equipped with a comfortable seat system, consisting of the established tour seat with hip-pads, an adjustable whitewater back belt with ratchets and individually adjustable 3D-thigh braces - which guarantees comfort and optimum contact to the kayak. The aluminum bulkhead footrest offers excellent hold and safety while the waterproof bulkhead in the rear and the day hatch in front offer enough storage for your next adventure.

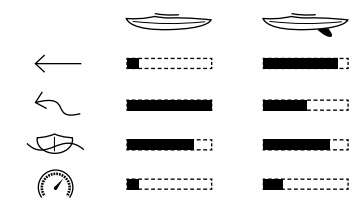
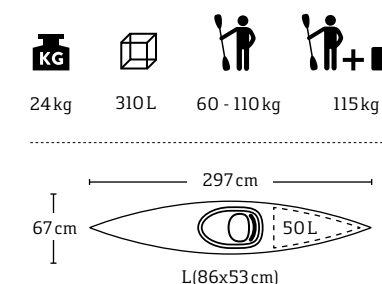



# DOUBLE SEATERS – DOUBLE PLEASURE

Our range of double-seaters consists of kayaks for rivers, lakes and the coast. Three models made of our carefree and everlasting HTP and three models made of lightweight fiberglass or carbon-aramid. All of them are equipped with our comfortable touring seat-system, minimum one bulkhead with waterproof storage and prepared for a steering.

The model DAYLINER DUO is pictured on page 31.  
All product images on page 35 show optional special colors.



## EXCURSION EVO HTP #10080

A very stable double-seater for your tour on rivers and lakes. The broad chines and a heavy rocker make it agile and glide easily around narrow bends. It has a very stiff hull thanks to our HTP.

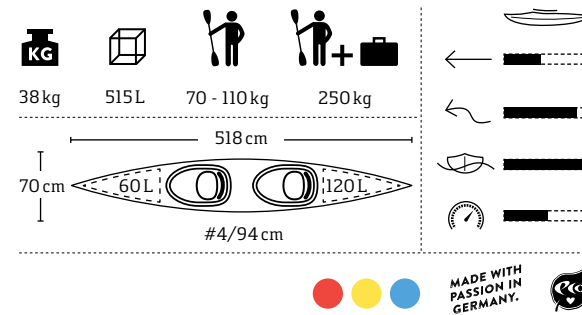

## POSEIDON HTP #10170

Touring double-seater for open waters and coastal tours with excellent tracking qualities and a pleasant travelling Velocity. Equipped with a comfortable seat-system, suitable for longer distances. One of our most stable kayaks.

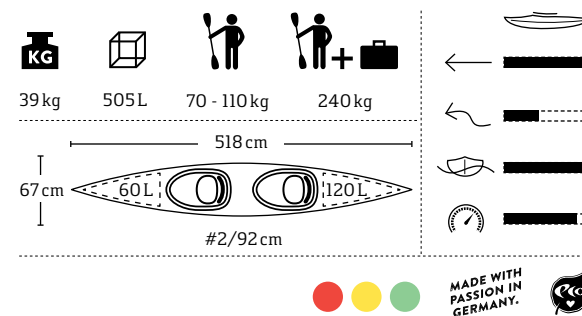

## PIAVE

GRP: #20892  
CARBON-ARAMID: #20894

First choice for paddlers, looking for a lightweight and easy to handle double-seater, which can easily be loaded on every car roof. High directional stability as well as agility and flip-stability. Made for lakes and larger rivers.

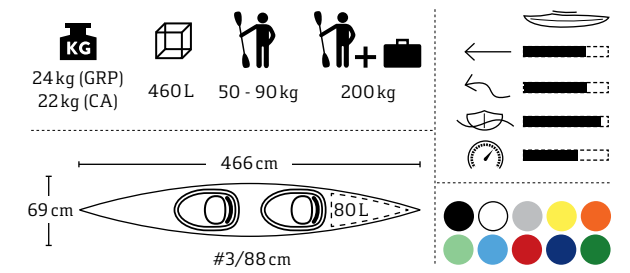

## YUKON K II SPORT

GRP: #20192  
CARBON-ARAMID: #20194

Stable and very fast double-seater, perfect for long tours across open waters. Large, watertight storage compartments and several mounting possibilities on deck offer ample space for your equipment. Very light!

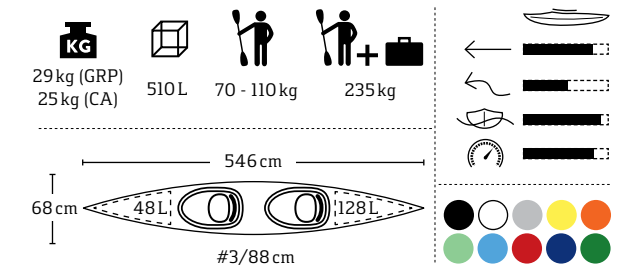

## YUKON K II RELAX

GRP: #20592  
CARBON-ARAMID: #20594

Open version of the Yukon K2 Sport. It's identical in length, width and lower boat. Thanks to the big open cockpit getting in and out of this kayak is made easy! A perfect touring kayak for inland waters with only light swell.

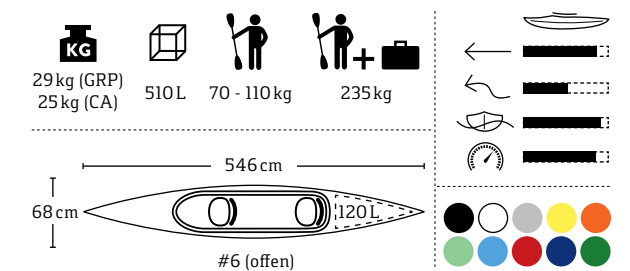



# CUSTOMLINE

Kayaks for beginners and casual paddlers. They are very stable, track well and are easy to maneuver. These boats are very well suited for short tours with little luggage or for kayak rental.

## FULL EQUIPMENT

Adjustable slide-footrest with steering fixtures | Tour-seat with padding | CL-backrest with padding and cover | waterproof bulkhead with cover in the rear | 2-D-thigh braces (not CL 470) | bungee deck rigging

## BASIC EQUIPMENT

Saw-tooth footrest with 5 fixed notches | Tour-seat with padding | CL-backrest with foam padding and cover | bungee deck rigging



### CUSTOMLINE 370 HTP

FULL EQUIPMENT: #110030

BASIC EQUIPMENT: #110010

Good tracking, high level of stability and agility. The large cockpit makes it easier to get in and out of the boat. Our tour seat with the high CustomLine backrest guarantees a comfortable sitting position.

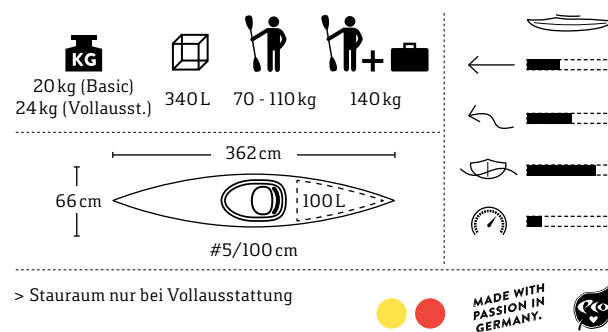

### CUSTOMLINE 430 HTP

FULL EQUIPMENT: #110330

BASIC EQUIPMENT: #110310

A very stable beginner kayak with easy handling. Perfect for lakes and calm waters. The extra-large cockpit offers an easy entry and exit. The tour-seat and high CustomLine-backrest guarantee a comfortable sitting position.

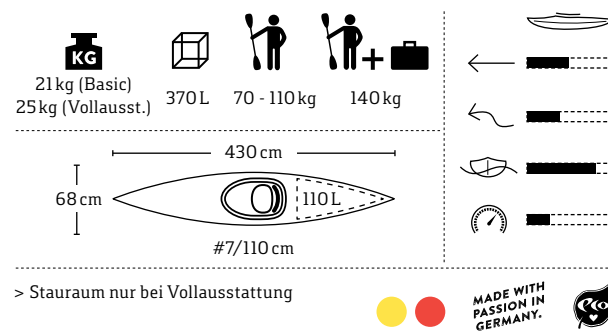

### OPTIONAL KIDS-SEAT CL 470

#90428

This optional child's seat can be added fast and easy and transforms your CL 470 RELAX into a three-seater family-kayak.



### CUSTOMLINE 470 RELAX HTP

FULL EQUIPMENT: #110230

BASIC EQUIPMENT: #110210

Paddling-fun for the whole family! Comfortable, open double-seater for lakes and calm waters. Offers a very high stability and easy handling. Made for couples, families and rental stations. An optional child's seat can be added quickly and easily.

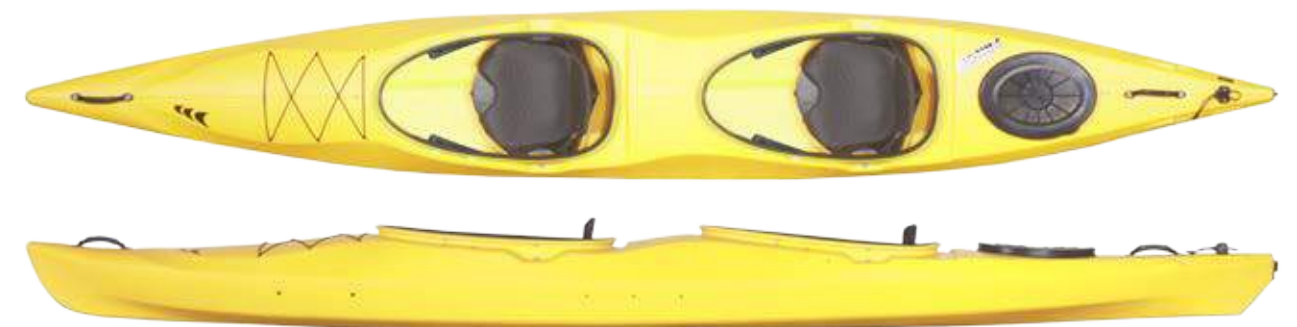
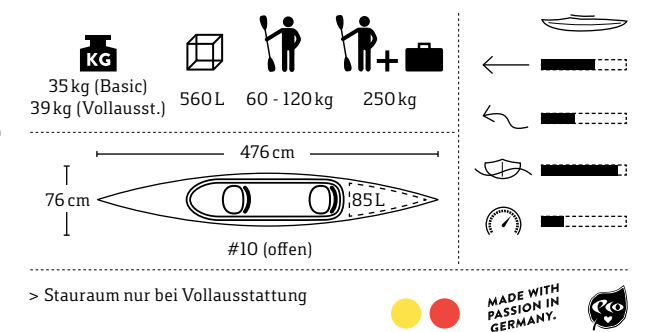

### CUSTOMLINE 490 HTP

FULL EQUIPMENT: #110130

BASIC EQUIPMENT: #110110

Double-seater for beginners. Excellent tracking and a high level of stability and agility. The large cockpits make it easy to get in and out of the boat. Tour seats with high backrests offer a comfortable sitting position.

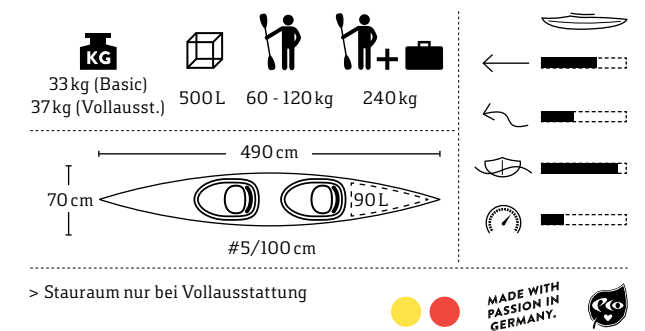





# KIDS EQUIPMENT

It's time to take the kids out on the water with you! We take a more serious approach on kayaking with children, so that your little ones can go paddling with the family. Basically, kids need the same equipment like adults - especially when they paddle for themselves. A PFD, functional wear, maybe a helmet and of course a kayak, that suits their needs and the planned trip. With our equipment, especially designed for kids, your

offspring can start the next family trip in the best possible equipped way. Because kayaking, exploring domestic rivers and lakes and spending an exciting day at the water with the family is great fun and brings your children playfully to healthy exercise. Nothing stands in the way of the next adventure with our kids equipment!



## SEAYAK JUNIOR PRO HTP

#100745

Excellent seakayak for kids! The length and width of the kayak, the size of the cockpit and the ergonomics have been perfectly adapted to suit the needs of children and teenagers. Thanks to its balanced riding qualities, it can keep up well with longer and larger boats, even over longer distances.

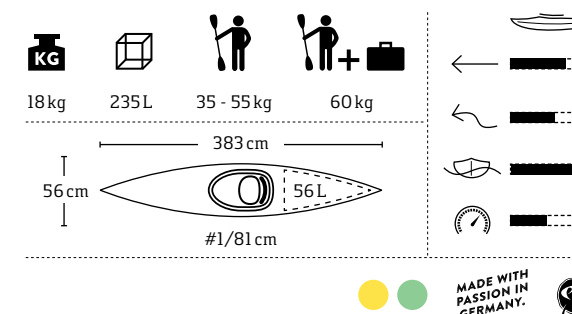

## RIM-BAMBINO

Blade size: 44 x 18,5 cm // Length: B // Weight: from 1080 g #313000

Paddle for kids and teenagers. Reduced Blade size and thinner shaft diameter for a better grip for small hands.



MADE WITH PASSION IN GERMANY.

## KID – BOUYANCY AID

Sizes: 1 (15 - 20 kg), 2 (20 - 30 kg), 3 (25 - 40 kg) #80040

Front zipper, chest and tummy belt for perfect fit, credch strap to prevent slipping out, unconscious-safe collar, signal whistle, large reflectors. Normed according to CE.





# PADDLE-FINDER

The first step to find the best paddle for you is to define its range of use. Next, narrow down the models according to your paddling style and physique. Based on the width of your kayak and your size you finally choose the correct length of your paddle.

If you're paddling a high angle technique, choose a shorter and wider blade. When you're more into low angle paddling, choose a rather longer and slimmer blade. In general, smaller paddlers pick smaller blades, taller and powerfully built paddlers pick large blades.

## WIDE AND SHORT ~

*For streams and whitewater*

Shorter and wider blades. Made for a high angle paddling technique, pulling the paddle close along the boat. Perfectly suitable for all-round kayaks.

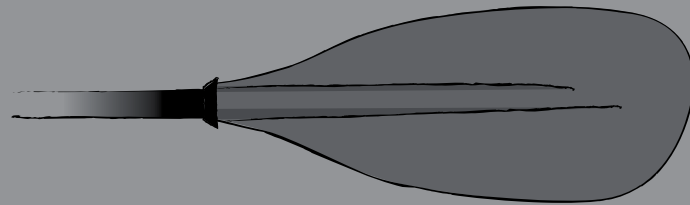

## LONG AND SLIM ~

*For the sea and open waters*

Longer and slim blades for low angle paddling techniques. Made for sea kayaking and touring on open waters.

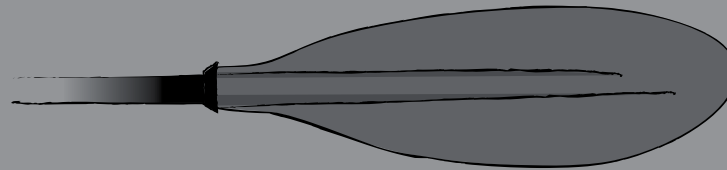

## MEDIUM SIZED ~

*For inland lakes and larger rivers*

These blades can be used both in high angle and low angle technique and offer good propulsion. Suitable for touring-, all-rounders- and seakayaks.

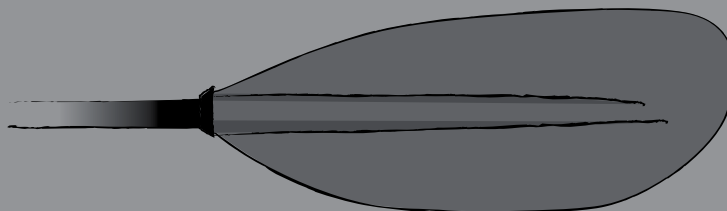

## FIND YOUR LENGHT ~

The opposite chart serves as a guideline for touring and seakayak paddles. We recommend a paddle with adjustable PaddLock shaft, to enable you to change the length and angle according to your requirements.

WIDTH OF KAYAK	55 - 59 cm	60 - 67 cm	> 68 cm
<b>BODY LENGTH</b>			
160 - 170 cm	210 - 215 cm	215 - 220 cm	220 - 230 cm
170 - 180 cm	215 - 220 cm	220 - 225 cm	230 - 240 cm
180 - 190 cm	220 - 225 cm	225 - 230 cm	230 - 240 cm
> 190 cm	225 - 230 cm	230 - 240 cm	230 - 240 cm



## LENGTH CHART

The product description of your desired paddle tells you in which lengths it is available. All paddles in fixed length come with a 45° right feather angle as a standard. Left feather angle on demand.

A	B	C	K	PaddLock	WW
210	180	130	190	210	190
215	185	140	195	220	195
220	190	145	197,5	230	197,5
225	195	150	200	240	200
230	200	155	202,5		202,5
240	205	160	205		205
	210		207,5		207,5
			210		

## BENT SHAFT

Some of our Whitewater- and Touring paddles are also available with a wrist-gentle, neutral and superlight carbon bent-shaft.



## PADDLOCK

All of our touring-paddles with 29mm-shaft are also available with the PaddLock-system. Their length is steplessly adjustable in a range of 10 cm; the feather angle of the blades can be adjusted freely. Small pack size, perfect for transporting.

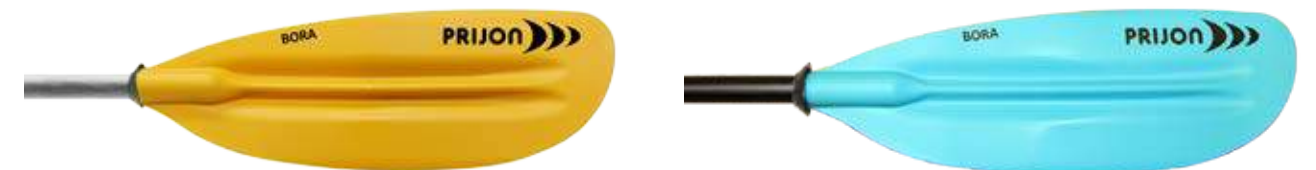

**BORA** Blade size: 51 x 17,5 cm // Length: A & PaddLock // Weight: from 970 g (Glass), from 1050 g (Glass & PaddLock)

Nicely shaped, allround profiled touring paddle with fiberglass shaft. Blades made of dry impact resistance polyamide 6 with UV stabilizers and approx. 35% part fibreglass. Very stiff and impact resistant.

**BORA Glass & PaddLock | mango**

#355000TS

**BORA Glass | mango**

#355000

**BORA Glass & PaddLock | blue**

#358000TS

**BORA Glass | blue**

#358000







**HYDRA** Blade size: 48 x 20 cm // Length: A & PaddLock // Weight: from 940 g (Glass), from 840 g (Carbon)

Lightweight touring- and seakayak paddle with large sized, stiff blades. For powerful paddlers it offers an optimized power transmission, a variety of different paddle strokes is possible. Works very well with high angle technique. Smaller blade size in the works.

HYDRA Carbon	#323000	HYDRA Glass   red	#326000
HYDRA Carbon PaddLock	#323000TS	HYDRA Glass   yellow	#328000
HYDRA Carbon ERGO	#323000E	HYDRA Glass PaddLock   red	#326000TS
HYDRA Carbon ERGO PaddLock	#323000ETS	HYDRA Glass PaddLock   yellow	#328000TS



**HYDRA S** Blade size: 47 x 19 cm // Length: A & PaddLock // Weight: from 900 g (Glass), ab 800 g (Carbon)

Our established Hydra seakayak- and touringpaddle with reduced blade size, which makes it even lighter. Its low flywheel mass, thanks to the light blades, makes a power-saving, endurance orientated paddling style possible. Made for sporty paddlers.

HYDRA S Carbon	#371000	HYDRA S Glass   red	#372000
HYDRA S Carbon PaddLock	#371000TS	HYDRA S Glass   yellow	#373000
HYDRA S Carbon ERGO	#371000E	HYDRA S Glass PaddLock   red	#372000TS
HYDRA S Carbon ERGO PaddLock	#371000ETS	HYDRA S Glass PaddLock   yellow	#373000TS



**KORNATI** Blade size: 51,5 x 18 cm // Length: A & PaddLock // Weight: from 910 g (Glass), from 795 g (Carbon)

Well-shaped, light touring paddle with midsized blades. Its slightly profiled blades with foam rib are very stiff and light, offer a good counter pressure and optimum gliding behavior through the water. Works very well for longer tours on lakes and the coast.

KORNATI Carbon	#344000	KORNATI Glass   red	#343000
KORNATI Carbon PaddLock	#344000TS	KORNATI Glass   yellow	#361000
KORNATI Carbon ERGO	#344000E	KORNATI Glass PaddLock   red	#343000TS
KORNATI Carbon ERGO PaddLock	#344000ETS	KORNATI Glass PaddLock   yellow	#361000TS



**STREAM** Blade size: 49 x 17,5 cm // Length: A & PaddLock // Weight: from 1020 g (Glass), from 880 g (Carbon)

Allround paddle for touring and seakayaking. Midsized, well-profiled paddle blade without a middle core. The blade is very stiff and does not flutter. Light, stiff and excellent power transmission.

STREAM Carbon	#318000	STREAM Glass   red	#317000
STREAM Carbon PaddLock	#318000TS	STREAM Glass   yellow	#366000
STREAM Carbon ERGO	#318000E	STREAM Glass PaddLock   red	#317000TS
STREAM Carbon ERGO PADDLOCK	#318000E TS	STREAM Glass PaddLock   yellow	#366000TS



**ESERA** Blade size: 45 x 19 cm // Length: A & PaddLock // Weight: from 870 g (Glass), from 1050 g (Glass & PaddLock)

Robust and stiff allround-paddle with glassfiber shaft and injection-molded blades with a slight mid rib. Made for beginners, advanced paddlers and rental stations. Short and wide, laterally radiused, asymmetric blades.

ESERA Glass & PaddLock   mango	#359000TS	ESERA Glass   mango	#359000
ESERA Glass & PaddLock   blue	#360000TS	ESERA Glass   blue	#360000



**RIM-ARDECHE**

Blade size: 48 x 19,5 cm // Length: A // Weight: from 1100 g

Economically priced allround and beginner paddle. Blade made of impact resistant RIM material. Aluminum shaft.

RIM-Ardeche	#314000
RIM-Ardeche separable	#314000TB



**RIM PAZIFIK**

Blade size: 53 x 16 cm // Length: A // Weight: from 1100 g

Seakayak paddle for beginners and rental stations. Blades made of robust RIM-material, shafte made of aluminum.

#315000
---------



**RIM-BAMBINO**

Blade size: 44 x 18,5 cm // Length: B // Weight: from 1080 g

Indestructible paddle for kids and teenagers. Reduced blade size, thinner shaft diameter for a better grip for small hands.

#313000
---------



**RIM-INDIAN** Blade size: 54 x 20 cm //

Length: C and 165 cm with loose grip // Weight: from 890 g

Tough canoeing and rafting paddle. Blade made of impact-resistant RIM material. Aluminum shaft.

#352000
---------



**RIM VESUVIO** Blade size: 49 x 18,5 cm //

Length: 165 cm with loose grip // Weight: from 730 g

Extremely robust dragon boat paddle, for trainings of hobby teams or rental stations. Blade made of sturdy RIM-material, shaft made of aluminum.

#357000
---------



**RIM CHIEMSEE**

Blade size: 46 x 23 cm // Length: 220 // Weight: 990 g

For SUP beginners and rental stations. Pleasant handling thanks to its own buoyancy. Uncut, detachable grip.

#351220U
----------





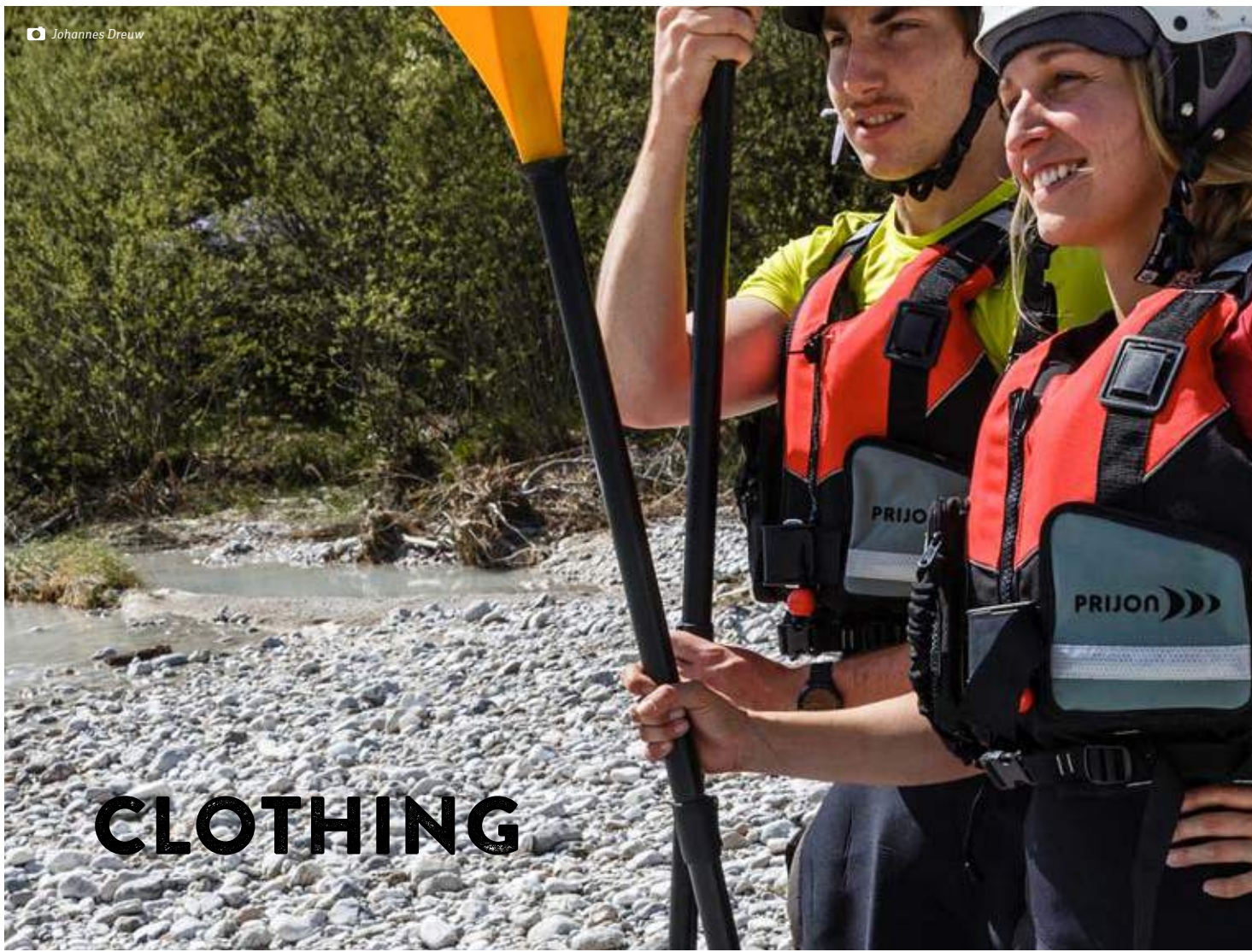

# CLOTHING



## PULLOVER NEOPRENE MICROFLEECE

Long-sleeved top.  
 Sizes: S | M | L | XL | XXL  
 #41550



## T-SHIRT NEOPRENE MICROFLEECE

Short-sleeved top.  
 Sizes: S | M | L | XL | XXL  
 #41350



## SHORTY NEOPRENE MICROFLEECE

Neoprene shorts with high waist.  
 Sizes: S | M | L | XL | XXL  
 #41450

Its tight cut and perfect fit makes microfleece neoprene perfect for competitive sport, summer paddling and for wearing under non-breathable paddling jackets. Upper lamination 100% Super-stretch Nylon. The microfleece lamination is pleasant to the skin and offers perfect ability to move. Neoprene in general protects the body from cooling down.



## FLOATER

Light touring vest with front zip, roundabout-strap to adjust the size, reflectors for better visibility and a crotch-strap to prevent the jacket from slipping up. Normed according to CE.  
 Sizes: S | M/L | XL/XXL  
 #80070



## MACH 2

Universally usable Touring- and Whitewater PFD. Equipped with a front zip, an enclosing strap system, hip belt, rescue belt with panic release, various pockets and reflective zones. Cowtail with carabiner. Normed according to CE.  
 Sizes: M/L | XL/XXL  
 #80080



## ANGLER

Inconspicuous and superlight vest for fishermen and touring paddlers, with front zip. Three large pockets and adjustable straps at the sides and shoulders. Normed according to CE.  
 Sizes: M/L | XL/XXL  
 #80030



## NEOPRENE SHOE LOW

Low-cut paddling bootie made of elastic neoprene with vulcanized sole. Light and flexible, perfect in narrow or competition kayaks.  
 Sizes: 35/36 | 37/38 | 39/40 | 41/42 | 43/44 | 45/46  
 #42400



## NEOPRENE SHOE HIGH

High-cut paddling bootie made of elastic neoprene with vulcanized sole. Warms and protects, especially the ankles. Perfectly fits in narrow boats.  
 Sizes: 35/36 | 37/38 | 39/40 | 41/42 | 43/44 | 45/46  
 #42300



## SUPERLIGHT CAP

Very thin cap out of 0,5mm superlight-neoprene. Keeps the head warm and fits under the helmet.  
 Sizes: Uni  
 #40700



## PADDLING PAWS

Protect the hands from wind and cold. One size fits all, made of 4mm - neoprene. Attachment around the paddle shaft with Velcro.  
 Sizes: Uni  
 #40840





# SPRAYDECKS & COCKPIT COVERS

During paddling, a spraydeck protects your torso and your legs from water dripping down or swashing waves and keeps the inside of the boat dry. The hatch cover protects the inside of the kayak during transport or storage. It further reduces the wind resistance and the road noise and saves fuel during transport. During storage, the inside of the kayak always remains dry and clean, dirt and vermin stay outside. We offer spraydecks and hatch covers in three different materials.

## NEOPRENE

- For continuous operation on rivers, lakes and the sea
- Stays on the cockpit in any case, even in choppy waters or when doing an Eskimo-roll
- Very flexible, will fit on various cockpits

## NYLON

- Basic spraydecks for touring on domestic waterways
- Protects against spray and rain
- Holds well on the boat
- New colors black/orange and black/grey plus some in red

## FLEX

- Very stretchable
- Superlight
- Small pack size
- Very good hold on the cockpit
- Resilience to wear is a bit lower than the neoprene

SIZE / MODELL:	SPRAYDECKS			COCKPIT COVERS
	Traveller orange	Traveller gray	Nylon red	Nylon Cockpit covers
1 (81cm) / for Seayak before 1997, Odyssee, Catalina	#74210	#74260		#78081
1 / for Seayak Junior			#74105	
2 (92cm) / for Seayak 520 HV, Seayak 500 LV, Dayliner L, Dayliner Duo, Munga, Poseidon	#74220	#74270		#78090
3 (88cm) / for PriLite Vellamo, PriLite Aruna, Skegyak HTP, PriLite Skegyak, Neptun, PriLite Marlin, PriLite Narva, PriLite Marlin LV, PriLite Senja, Barracurda RS, Seayak Classic, Marlin LV Laminat, Predeus, Falcon, Millenium Evo, Touryak 470, Dayliner S, Yukon K2 Sport, Piave	#74230	#74280		#78035
4 (94cm) / for Grizzly, Enduro 450, Enduro 380, Touryak 500, Excursion Evo	#74240	#74290		#78091
5 (100cm) / for CL 370, CL 490, PriLite Vellamo	#74250	#74300		#78095
6 (offen) / for Yukon K2 Relax			#74180	#78180
7 (110cm) / for CL 430 und alle Cruiser	#74255	#74310	#74190	#78020
10 (open) / for CL 470 Relax			#74160	#78190
11 / for Seatron GT	#74245	#74295		#78091



### TOURING SPECIAL NEOPRENE SPRAYDECK

Premium quality touring- and seayak spraydeck. Very stretchable deck with abrasion-resistant area at the front, knee belt and grip sling. Latex coat on the inside, excellent hold, even on wet cockpit rims. Waist made of breathable 3-layer laminate for a comfortable fit. Waist size can be individually adjusted. Removable shoulder straps.

- 84 - 88 cm #73750
- 92 - 96 cm #73700
- 95 - 105 cm #73760
- SEATRON GT #73770



### TOURING BASIC NEOPRENE SPRAYDECK

For touring paddler, easy whitewater or rental stations. Extremely stretchable deck, two deck sizes, fits cockpits from 86 to 96 cm. Waist made of breathable 3-layer laminate. The very stretchable neoprene band provides a watertight hold on the body.

- 86 - 92 cm | S/M #73801
- 86 - 92 cm | L/XL #73802
- 90 - 96 cm | S/M #73803
- 90 - 96 cm | L/XL #73804



### FLEX SPRAYDECK

Superlight, high-quality spraydeck made of stretchy Nylon material with waterproof lamination. Perfect fit due to their neoprene-like stretchability; very light weight and small pack size.

- 81 - 88 cm #74500
- 88 - 94 cm #74550
- 95 - 102 cm #74600



### NYLON SPRAYDECK TRAVELLER ORANGE OR GREY WITH REFLECTORS

Robust, universally usable spraydeck for beginners, advanced paddlers and rental stations. Made of sturdy but soft and light Nylon material. All seams are welded. The plate is reinforced with a bracket. Equipped with a mesh pocket with reflective stripes at the front, removable shoulder straps. Waist size adjustable.

Sizes, article numbers and prices see adjoining chart <



### NEO COCKPIT COVER

Stays super safe on the boat without fluttering. Fits different cockpit sizes.

- 81 - 85 cm #78210
- 88 - 93 cm #78200



### NYLON COCKPIT COVER

Made of super sturdy PVC-laminated material and available in different hatch sizes.

Sizes, article numbers and prices see adjoining chart <



### FLEX COCKPIT COVER

Noble optic. Stretches similar to neoprene. Can be stored easily due to its low weight and small pack size.

- 81 - 88 cm #78230
- 88 - 94 cm #78235
- 95 - 102 cm #78240



# BAG & BAGGAGE



## DECKMASTER

Reflective, watertight deck bag with shoulder straps. Equipped with a net-bag with zip, lateral loops and straps for attachment on your kayak. Reflectors for more safety!

**orange**  
 XL: 23 L | 690 g |  
 with shoulder straps | #44047  
 M: 13,5 L | 680 g |  
 with paddlefloat-feature | #44048

**grey**  
 XL: 23 L | 690 g |  
 with shoulder straps | #44027  
 M: 13,5 L | 680 g |  
 with paddlefloat-feature | #44028



## TOPBOX

Additional and mobile storage for your kayak. Just clip and fix in on your kayak, or take it with you. Equipped with a handle and safety leash with carabiner. Fits on the PriLite Narva, Dayliner S and L and with the optionally available mounting kit on all other HTP-kayak without day hatch.

**TopBox** #90027  
**Optional mounting kit** #90025



## MAP SLEEVE

Watertight, see-through, with four plastic carabiners for the fixation on the kayak. Two different sizes.

**DIN A4** #44021  
**DIN A3** #44026



## DECK BAG

Made of sturdy Nylon material with welded seams, can be mounted in front or behind the cockpit. Roll-click closure with safety belt, handle and loops for attachment.

#44020



## MULTIBAG YELLOW

Waterproof dry bags, made of high-quality material with rolltop-closure. Sturdy and simple to use. With detachable shoulder strap.

Color: yellow

5L	#44050
10L	#44051
15L	#44052
20L	#44053
30L	#44054
40L	#44055



## MULTIBAG BLACK

Waterproof dry bags, made of high-quality material with rolltop-closure. Sturdy and simple to use.

3L	#44009
8L	#44008
12L	#44010
20L	#44011
40L	#44012
60L	#44013



## CELLPHONE BAG

Floating, waterproof nylon bag with valve for easy inflation, to ensure your mobilephone stays safe while paddling. With safety loop and belt clip.

**XL (Phone size: 15 x 10 cm)**  
 #44029



# ACCESSORIES



## CANOE SEAT

Padded canoe seat for additional installation. Incl. straps for attachment. Upper material 100% Nylon.

#90162



## SEAT- / BACKREST PAD

Upgrade your Prijon touring seat and increase the comfort in your kayak!

Seatpad: #1000042

Backrest pad: #1000041



## SEAT PAD WITH LUMBAR SUPPORT

The included lumbar support can be adjusted via the backrest. Made of sturdy Nylon material with included seat foam padding. The backrest is cushioned with a preformed foam wedge. Suitable for many different types of seats.

#90161



## BILGE PUMP

To remove water from the kayak after capsizing or in case of leakage. An essential when paddling in the sea.

#90123



## VACO SEAT CUSHION

Seat cushion for the PRIJON tour seat, filled with plastic beads.

Can be adjusted with a vacuum pump to perfectly fit the individual seat shape of the paddler. Sit down - pump - feel comfortable!

#90169



## TOWLINE

Rescue equipment for tourers and sea kayakers with a 10 m-rope length and a carabiner. To pull other paddlers or empty boats. Fixed around the torso.

#80178



## STEERING

Fully folding steering for PRIJON kayaks. With a profiled, flow-optimized steering blade, made of fibre-reinforced plastics. Fits all PRIJON kayaks prepared for steering. Tracking and agility can be positively influenced by the use of a steering system.

LUXUS K I

#90524

LUXUS K II

#90517

MADE WITH PASSION IN GERMANY.



## PADDLE LEASH

Keeps your paddle safe and connected to the boat. Made of 25mm tubular strap with integrated rubber cord and a Velcro closure for attaching it to the paddle.

#90180



## PADDLEFLOAT

Two products in one! To build a stabilizing outrigger, e.g. for reentering the kayak after flipping. Or as a flat packbag, for watertight transport of equipment.

#80330



## POLISH PASTE

For surface care and removal of minor scratches on PriLite kayaks.

#90092



## BULKHEAD GLUE

To glue foam bulkheads in kayaks.

#90000902



## REPAIR STICKS

For repairs of minor damages on HTP hulls. Available in different colors.

#90080

MADE WITH PASSION IN GERMANY.



## GLUE

Glue for protecting caps, stern mountings and other waterproofing actions.

#90096



# BOAT CARTS

For the transport from the car to the water and back, or in the case of it being necessary to walk some considerable distance during a trip on a river. We offer a wide range of boat carts. The choice is made according to the type of the kayak and the required pack size. Smaller, lighter carts can easier be stored in the kayak, larger carts with large wheels run better through rough terrain and do not sink in soft terrain. All of our boat carts are "Made in Germany".



BOAT CARTS	Positioning	Type of kayak	Terrain	Load
V-Shape S	Rear	Slim seakayaks	Tar, gravel, grassland	Medium
V-Shape L	Rear	Slim seakayaks	Tar, gravel, grassland	Medium
Steel S	Center	Light to medium weight single kayaks	Tar, gravel, grassland	Low
Steel L	Center	Light to heavy single and double kayaks	Tar, gravel, grassland	Medium
Daytourer S	Rear	Light single kayaks	Tar, gravel, grassland	Medium
Day Tourer L	Rear	Light to heavy single kayaks	Tar, gravel, grassland	Medium
Cart with support	Center	Double-seaters and canoes	Tar, gravel, grassland mud, sand	Heavy
Crossover	Center	Light to heavy single and double kayaks	Tar, gravel, grassland mud, sand	Heavy
Crossover Light	Center	Light to heavy single and double kayaks	Tar, gravel, grassland	Heavy

## BOAT CART WITH SUPPORT

Freestanding cart with voluminous air tires! Excellent ground clearance, cargo straps included. Very strong and stable.

Made for the transport of big kayaks, doubles and Canoes.

**Material:** Stainless steel | **Capacity:** ca. 110 kg | **Wheel size:** 25 x 8 cm | **Weight:** approx. 2,6 kg  
#90193



## V-SHAPE S & L



Designed for slim kayaks with seakayak type keel line and bottom. Thanks to the strong and elastic rubber band, it is mounted on the kayak within seconds. Optimized for the transport from the car to the water or a portage during the trip. The lengthwise rubberized stems keep the kayak safely and without slipping on the cart. Consists of only three parts and is super-easy to dismount.

### V-SHAPE S

**Material:** Stainless steel | **Capacity:** ca. 90 kg | **Wheel size:** 19,5 x 4,5 cm | **Weight:** approx. 1,6 kg

#90205

### V-SHAPE L

**Material:** Stainless steel | **Capacity:** ca. 100 kg | **Wheel size:** 27 x 6 cm | **Weight:** approx. 2,6 kg

#90213



## DAYTOURER S & L



Very small packing size! Equipped with a strong and elastic bungee tie-down strap to be attached to the boat within seconds. Perfect for short transport from the car to the water or for short portages! The "L"-version frame is a bit wider, so that it can be mounted a bit further towards the middle of the boat. It also has larger wheels, so that it rolls more easily.

### DAYTOURER S

**Material:** Stainless steel | **Capacity:** ca. 90 kg | **Wheel size:** 19,5 x 4,5 cm | **Weight:** approx. 1,8 kg

#90191

### DAYTOURER L

**Material:** Stainless steel | **Capacity:** ca. 100 kg | **Wheel size:** 27 x 6 cm | **Weight:** ca. 2,0 kg

#90187



## CROSSOVER & CROSSOVER LIGHT



Due to its round cushions it's suitable for all boat hulls from seakayaks to canoes. Fully dismountable, with PU foam wheels or broad air wheels. Fits into narrow storage spaces. Cargo straps included.

### CROSSOVER

**Material:** Aluminum | **Capacity:** ca. 120 kg | **Wheel size:** 25 x 8 cm | **Weight:** approx. 3 kg

#90186

### CROSSOVER LIGHT

**Material:** Aluminum | **Capacity:** ca. 120 kg | **Wheel size:** 27 x 6 cm | **Weight:** approx. 2,7 kg

#90190



## STEEL S & L



Made of stainless steel and therefore absolutely corrosion-free. The plug-in technology with springs made of stainless steel permits a construction without loose bits and pieces. PU foam wheels have a very light weight, the wheels cannot lose air! Small pack size when dismantled in its five pieces!

### STEEL S

**Material:** Stainless steel | **Capacity:** ca. 55 kg | **Wheel size:** 19,5 x 4,5 cm | **Weight:** approx. 1,8 kg

#90192

### STEEL L

**Material:** Stainless steel | **Capacity:** ca. 100 kg | **Wheel size:** 27 x 6 cm | **Weight:** approx. 2,5 kg

#90197







## TRANSPORT SYSTEMS

Our range of transport systems offers you a lot of aid in the transport and handling of your kayak. It starts with the loading on the roof of your car. In any case, you need an officially approved base support bar. These bars are available at specialist retailers. Please consider the legal regulations regarding roof load, lengths, overhangs and labeling requirements when transporting your kayak on the roof of the car. All products of our transport systems range (except the Master Lock) are "Made in Germany".

### LOAD ASSIST

Loading your boat made easy! Our load assist makes it possible for one person to load a kayak without any extra help, because you never have to lift the whole weight of the kayak. No difficult balancing to do. Fits nearly every roof rack. By sitting behind the bar it is protected from the airstream while driving. Incl. mountings and instruction manual.

#90264

MADE WITH PASSION IN GERMANY.



### TIE-DOWN STRAPS

Made of Polypropylene with self-locking metal buckle. Certified according to EN 121 95-2.

3,5m #90240

5m #90250

MADE WITH PASSION IN GERMANY.

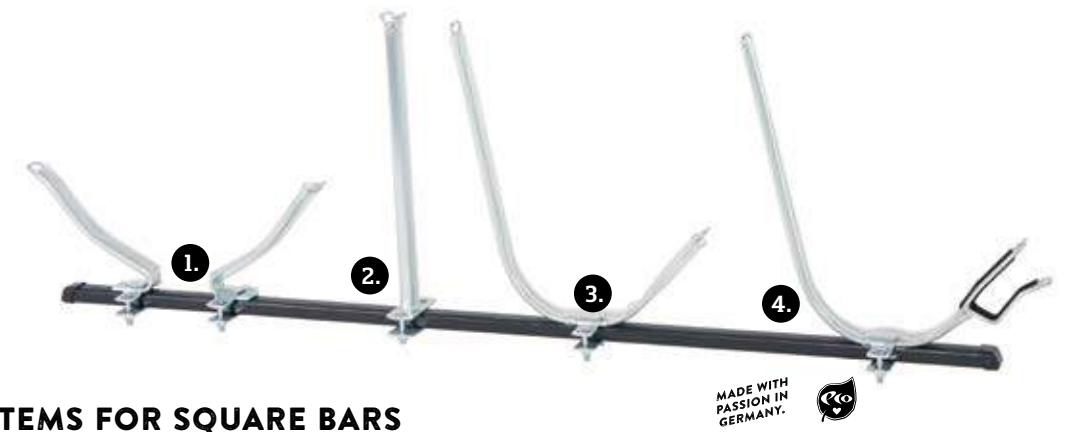

### TRANSPORT SYSTEMS FOR SQUARE BARS

#### 1. ¼-bar for kayaks and canoes | #90221

For the recumbent transport of canoes and large kayaks. Set of 4. Made of galvanized steel.

#### 3. J-bar | #90210

Cautious option to transport your kayak, as the pressure is evenly distributed around the hull. Set of 2. Made of galvanized steel.

#### 2. Vertical support bar | #90219

Perfect solution to transport several kayaks. Belts can be strapped down to both sides. Set of 2. Made of galvanized steel.

#### 4. J-bar with paddle holder | #90215

For the safe transport of one kayak and 2 paddles. Spreads the pressure around the hull and protects your kayak, paddles do not require an extra strap. Set of 2. Made of galvanized steel.

### TRANSPORT SYSTEMS FOR BARS WITH GROOVE

#### 1. ¼-bar for kayaks and canoes | #90217

Stainless steel. For the recumbent transport of canoes or large kayaks. Set of 4.

#### 2. Vertical support bar - rigid | #90223

Galvanized steel. Ideal solution for the transport of several kayaks. Belts can be strapped down on both sides. Set of 2.

#### 3. J-bar, galvanized steel | #90224

Galvanized steel. For the protecting and safe transport of your kayak. Set of 2.



### FOAM PADDING

Foam padding for square bars. Smooth transport, prevents the kayak from slipping. Set of 2.

#90236

MADE WITH PASSION IN GERMANY.



### ADAPTER

Adapter for attaching our square roof rack equipment on bars with groove. Set of 2.

#90226

MADE WITH PASSION IN GERMANY.





High Five Kayaking

## KAYAK-SCHOOLS

### **PRIJON KAYAK SCHOOL AUGSBURG**

Our kayak school, run by headmaster Annika Seidl, sits at the whitewater course in Augsburg. We offer whitewater-courses for every skill level in Augsburg, various rivers in Bavaria, Austria and Slovenia. Safety is our top priority. We use our elaborate training concept to teach you an excellent technique and instruct you to become responsible paddlers, which are able to evaluate dangerous situations using your own skills. We also offer accessible kayaking for people with disabilities. We are looking forward to your visit on our website and your participation in one of our courses.

### **PRIJON SPORT CENTER SLOWENIEN**

In our Kayak School at Prijon Sport Center in Bovec/Slovenia, we look forward to welcoming participants of all backgrounds and experience in one of our courses. Complete beginners will be familiarized with the kayak equipment, basic paddling techniques, and the magnificent Soča river. Those with a bit more experience can upgrade their knowledge with advanced courses, but no matter how experienced you are, we will make sure you enjoy river wonders, teach you how to respect it and above all recognize its traps and thus become a better and safer paddler.

W [www.kajakschule-prijon.com](http://www.kajakschule-prijon.com)  
E [kontakt@kajakschule-prijon.com](mailto:kontakt@kajakschule-prijon.com)  
T 0049 (0) 151- 15227419







T +386 5 388 67 20  
M +386 41 528 767  
E [info@prijon-sportcenter.si](mailto:info@prijon-sportcenter.si)  
W [www.prijon-sportcenter.si](http://www.prijon-sportcenter.si)



























































# DATA DIRECTORY

MODEL / MATERIAL	LENGTH / WIDTH	 KG				STORAGE TOTAL	COCKPIT
<b>WHITEWATER KAYAKS</b>							
Pike   HTP	273 cm / 61 cm	20 kg (Pro) / 18 kg (Sport)	250L	60 - 90 kg	-	-	L (86x53 cm)
Cocaine   HTP	275 cm / 65 cm	22 kg (Pro) / 20 kg (Sport)	305L	65 - 95 kg	-	-	L (86x53 cm)
Curve 2.5 HTP	258 cm / 66 cm	20 kg (Pro) / 18 kg (Sport)	250L	60 - 85 kg	-	-	L (86x53 cm)
Curve 3.0 HTP	268 cm / 68 cm	22 kg (Pro) / 20 kg (Sport)	300L	75 - 115 kg	-	-	L (86x53 cm)
Curve Creek 3.5 HTP	268 cm / 68 cm	23 kg (Pro) / 21 kg (Sport)	330L	75 - 115 kg	-	-	L (86x53 cm)
2B   HTP	372 cm / 69 cm	37 kg	540L	190 kg (total)	-	-	L (86x53 cm)
<b>FAST SINGLE-SEATERS</b>							
Seatron GT   HTP	520 cm / 58 cm	29 kg	390L	75 - 120 kg	140 kg	170L	#11 (94 cm)
Seayak Classic HTP	490 cm / 58 cm	27 kg	360L	65 - 90 kg	120 kg	152L	#3 (88 cm)
Seayak 500LV HTP	500 cm / 55 cm	26 kg	329L	50 - 80 kg	100 kg	145L	#2 (92 cm)
Seayak Junior Pro HTP	383 cm / 56 cm	18 kg	235L	35 - 55 kg	60 kg	56L	#1 (81 cm)
Aruna PriLite	509 cm / 55 cm	24 kg	330L	60 - 100 kg	120 kg	157L	#3 (88 cm)
Grizzly HTP	518 cm / 61 cm	29 kg	415L	80 - 120 kg	160 kg	200L	#4 (94 cm)
Marlin Prilite	530 cm / 58 cm	23 kg	375L	80 - 115 kg	140 kg	180L	#3 (88 cm)
Marlin Prilite LV	513 cm / 58 cm	22 kg	340L	55 - 95 kg	115 kg	155L	#3 (88 cm)
<b>LAMINATED SINGLE-SEATERS</b>							
Neptun   GRP / CA	522 cm / 57 cm	22 kg (GRP) / 20 kg (CA)	375L	80 - 120 kg	130 kg	167L	#3 (88 cm)
Falcon   GRP / CA	490 cm / 55 cm	17 kg (GRP) / 14 kg (CA)	320L	55 - 90 kg	100 kg	-	#3 (88 cm)
Barracuda RS   GRP / CA	518 cm / 55 cm	19 kg (GRP) / 16 kg (CA)	335L	60 - 90 kg	100 kg	99L	#3 (88 cm)
Marlin LV   GRP / CA	507 cm / 57 cm	20 kg (GRP) / 17,5 kg (CA)	335L	55 - 95 kg	115 kg	146L	#3 (88 cm)
Millenium Evo   GRP / CA	505 cm / 59 cm	20,5 kg (GRP) / 19 kg (CA)	360L	65 - 95 kg	125 kg	167L	#3 (88 cm)
Proteus   GRP / CA	520 cm / 57 cm	21 kg (GRP) / 19,5 kg (CA)	385L	75 - 110 kg	140 kg	185L	#3 (88 cm)
<b>ALLROUNDERS</b>							
Touryak 500 HTP	503 cm / 63 cm	28 kg	455L	75 - 120 kg	160 kg	191L	#4 (94 cm)
Touryak 470LV HTP	470 cm / 59 cm	26 kg	360L	55 - 85 kg	115 kg	153L	#3 (88 cm)
Enduro 450 HTP	453 cm / 62 cm	27 kg	380L	70 - 115 kg	130 kg	154L	#4 (94 cm)
Enduro 380 HTP	380 cm / 67 cm	25 kg	348L	65 - 110 kg	115 kg	130L	#4 (94 cm)
Dayliner S HTP	387 cm / 61 cm	22 kg	319L	50 - 70 kg	80 kg	105L	#3 (88 cm)
Dayliner L HTP	423 cm / 64 cm	25 kg	380L	60 - 105 kg	120 kg	137L	#2 (92 cm)
Narva Prilite	407 cm / 62 cm	19 kg	380L	60 - 105 kg	115 kg	93L	#3 (88 cm)
Prilite Vellamo	330 cm / 69 cm	18 kg	370L	60 - 105 kg	115 kg	90L	#5 (97 cm)
Munga HTP	297 cm / 67 cm	24 kg	310L	60 - 110 kg	115 kg	50L	L (86x53 cm)
<b>DOUBLE-SEATERS</b>							
Excursion Evo HTP	518 cm / 70 cm	38 kg	515L	70 - 110 kg	250 kg	180L	#4 (94 cm)
Poseidon HTP	518 cm / 67 cm	39 kg	505L	70 - 110 kg	240 kg	180L	#2 (92 cm)
Dayliner Duo   HTP	470 cm / 68 cm	35 kg	480L	50 - 90 kg	200 kg	112L	#2 (92 cm)
Piave   GRP / CA	466 cm / 69 cm	24 kg (GRP) / 22 kg (CA)	460L	50 - 90 kg	200 kg	80L	#3 (88 cm)
Yukon KII Sport   GRP / CA	546 cm / 68 cm	29 kg (GRP) / 25 kg (CA)	510L	70 - 110 kg	235 kg	176L	#3 (88 cm)
Yukon KII Relax   GRP / CA	546 cm / 68 cm	29 kg (GRP) / 25 kg (CA)	510L	70 - 110 kg	235 kg	120L	#6 (open)
<b>CUSTOM LINE</b>							
Customline 370 HTP	362 cm / 66 cm	20 kg (Basic) / 24 kg (Full-version)	340L	70 - 110 kg	140 kg	100L	#5 (100 cm)
Customline 430 HTP	430 cm / 68 cm	21 kg (Basic) / 25 kg (Full-version)	370L	70 - 110 kg	140 kg	110L	#7 (110 cm)
Customline 470 Relax HTP	476 cm / 76 cm	35 kg (Basic) / 39 kg (Full-version)	560L	60 - 120 kg	250 kg	85L	#10 (open)
Customline 490 HTP	490 cm / 70 cm	33 kg (Basic) / 37 kg (Full-version)	500L	60 - 120 kg	240 kg	90L	#5 (100 cm)

# CHARACTERISTICS



# MATERIALS & CARE

## HTP - High performance-Thermoplast

For the production of our HTP-kayaks, we are using a special Polyethylen - our unique HTP. This material can only be used in blow-moulding and not in roto-moulding production, as used by other producers of kayaks. The molecule chains of HTP are approximately 10 times longer than those of rotated PE. This makes the boat hulls stiffer, lighter and less susceptible to abrasion. HTP-kayaks have clear advantages regarding form stability, abrasion and boat weight, compared to kayaks made of roto-moulded PE. HTP is very environmentally friendly. When it is recycled, there are no poisonous gases or residues; it is ground water neutral and free of heavy metals.

## Care:

HTP-boat shells are very sturdy and already possess a permanent protection against UV-rays. Therefore they need no treatment with varnishes, wax or other care materials.

- Extremely high mechanical durability
- Lighter PE-hulls than roto-moulded kayaks
- Not sensitive to ground impact
- Stiff and form-stable during paddle tours in the Arctic and the Tropics
- Recyclable

## PriLite

For PriLite boats, the ABS-combination plates, sealed with UV-resistant Perspex, are pulled into the hot moulds, which have a temperature of approximately 80 degrees, in a computerized process, using heat and vacuum. Top and bottom are inseparably joined together by a double-sided U-profile. This profile additionally strengthens the sides of the kayak against impact. The fitting of deck mountings and interior fittings are done by hand, as on all Prijon boats. Advantages: PriLite boats are approx. 20 % lighter than comparable kayaks made of HTP. At the same time there is a clear advantage regarding stability compared to GRP or Carbon/Aramide.

## Repairs/Care:

Superficial scratches can be polished off with a special paste, available in specialized shops. Larger repairs are made with Epoxy. The inside of the boat should not be permanently exposed to sun (store upside down!).

- Lighter than HTP
- More sturdy than GRP/Carbon Aramide
- Unique metallic colours

## Carbon-Aramide

These boats mainly consist of carbon and aramide fibres, combining the excellent qualities of carbon, which is very hard and gives the boat its stiffness with the qualities of aramide, which is very shock-proof and provides the necessary impact resistance of the kayak. The biggest advantage of this construction method is clearly the incredibly low weight.

- Lighter than HTP and PriLite (up to 10 kg less than a HTP kayak at the same length)
- Elegant shape
- Stiff hull
- Easy handling outside of the water due to its low weight

## GRP

The fibre mats of our GRP-kayaks mainly consist of fibre glass, which is very stiff, but still reasonably priced. Kayaks made of GRP are comparable to the PriLite boats with regard to their weight and are around 20% lighter than HTP kayaks.

- Lighter than HTP and PriLite (approx. 5 kg less than a HTP kayak at the same length)
- Elegant shape
- Stiff hull
- Easy handling outside of the water

# IMPRINT

This catalogue is valid from 01.01.2022 to 31.12.2022. Prijon products are exclusively sold by specialist dealers, a list is available on our website [www.prijon.com](http://www.prijon.com). We are also happy to send a list of our dealers to you by post. Prijon reserves the right to technical and color changes, all marketing materials may contain possible printing errors. Responsible: Max Pernreiter.

Prijon GMBH | Innlande 6 | 83022 Rosenheim

T +49 8031 30370  
F +49 8031 303799  
E [info@prijon.com](mailto:info@prijon.com)  
W [prijon.com](http://prijon.com)

[facebook.com/prijonkayakpaddles](https://www.facebook.com/prijonkayakpaddles)  
[instagram.com/prijongmbh](https://www.instagram.com/prijongmbh)

Design & Layout



Rapp Design

W [www.sebastianrapp.de](http://www.sebastianrapp.de)  
E [info@sebastianrapp.de](mailto:info@sebastianrapp.de)

This catalogue is printed on paper from responsibly managed sources.





